



FRANK

BY NEWTECH

INSTALLATION INSTRUCTIONS PRODUCT CARE & WARRANTY INFORMATION



IMPORTANT

Thank you for purchasing one of our products. **NEWTECH RECOMMENDS THAT A QUALIFIED TRADESPERSON INSTALL THIS PRODUCT AND THAT IT IS INSTALLED TO A PROFESSIONAL STANDARD.**

This product carries a full warranty against faulty workmanship and materials. Please inspect for damage before installation. It is the responsibility of the installer to make any necessary adjustments to doors and drawers after installation if required.

Preparation



IMPORTANT - ARE YOU INSTALLING THIS PRODUCT?

Please **READ** the installation instructions in this booklet **BEFORE INSTALLATION**. Newtech recommends that a qualified trades person install this product and that it is installed to a **professional standard**, in accordance with this instruction booklet. Failing to do so may void the warranty. This product carries a full warranty against faulty **workmanship and materials**. Please inspect for damage before installation. It is the responsibility of the installer to **make any adjustments** to doors/drawers after installation if required.

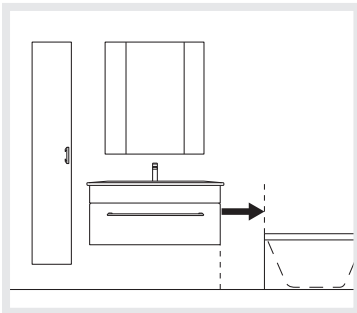

POSITIONING & VENTILATION

- The floor needs to be level and the wall straight.
- A gap of at least 150mm needs to be left between a bath and vanity unit.
- Do not expose vanity unit to shower spray.
- A water barrier, e.g. a glass shower panel needs to be between any vanity unit and shower
- It is important that the bathroom is adequately ventilated as high humidity can lead to deterioration of materials.

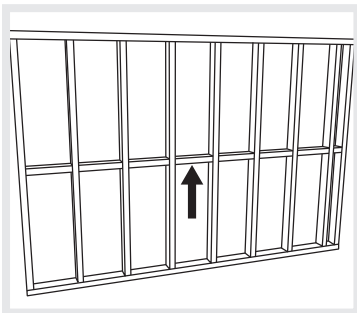

1. CHECK SUPPORT NOGS

Wall hung furniture and wall hung ceramic basins require fixing to support noggs fitted between the studs, as detailed, to give a solid wall backing to attach the vanity. If necessary fix additional support noggs at desired height for cabinet and basin fixing. Ensure total width of support nog exceeds vanity width. Refer to step 6b 'fixing basins'

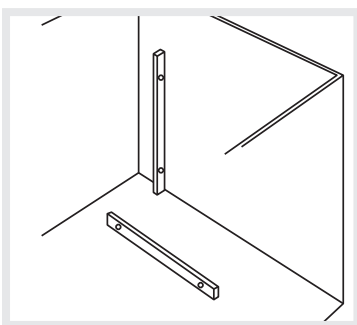

2. ENSURE WALLS ARE PLUMB AND FLOORS ARE LEVEL

Ensure the Wall is plumb and straight, ensure floor is level. If you fix the product to a non-plumb wall or floor the following will happen:

- Your door or drawers will not operate correctly
- Door or drawer adjustments will not align.
- Basins will not sit level, which may cause water to pool or not drain correctly

If it is not possible to make the wall or floor plumb and straight you must pack the vanity out so that it does not follow the out of aligned wall.

Floor standing vanities must sit on a level floor or be packed to sit level and true.

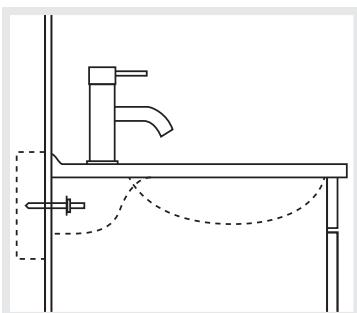

3. CHECK PLUMBING POSITIONS PROPERLY ALIGN

Measure and mark the cabinet for the location of waste and hot/cold water supply. Drill from the inside of the cabinet using appropriately sized holesaw.

Note: If your product has any electrical fittings please allow for this and talk to your electrician.

Vanity Unit Installation

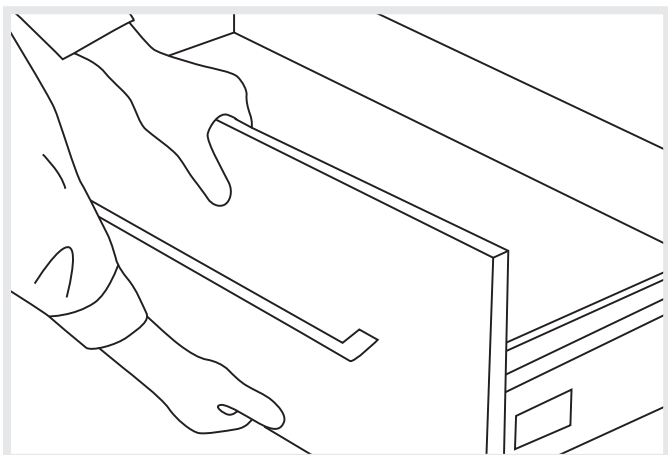

PREPARE THE CABINET

Remove doors & drawers and drill holes for plumbing in the back panel and/or base of the cabinet with an appropriate sized hole saw. Pre-drill screw locations for fastening to wall - see p6.

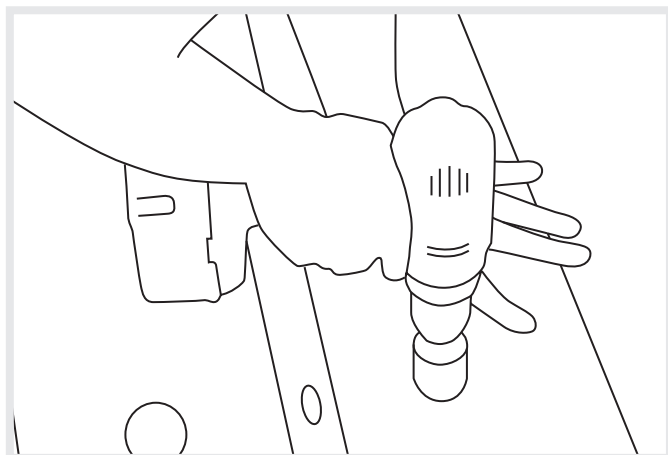

TAP HOLE

StoneCast Stab Tops require a tap hole to be drilled. We recommend using a Blue-Mole 35mm hole saw. Ensure to drill the hole from the top of the basin.

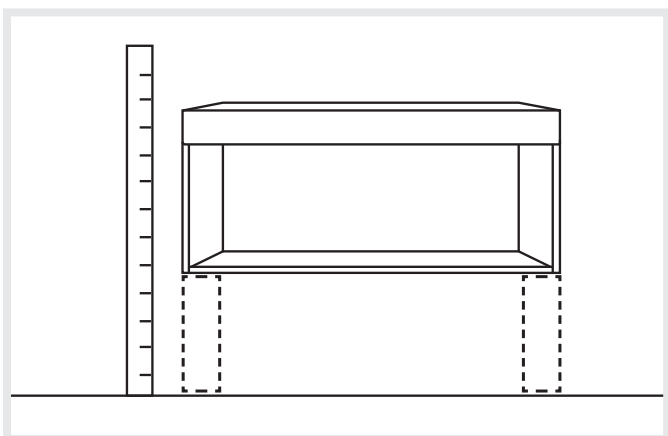

MEASURE UP

Mark the position of the top of the vanity - factor in the top/basin thickness to get the correct height. Use a single screw in centre of vanity, or use some support stands to hold the cabinet in place, ready for installation.

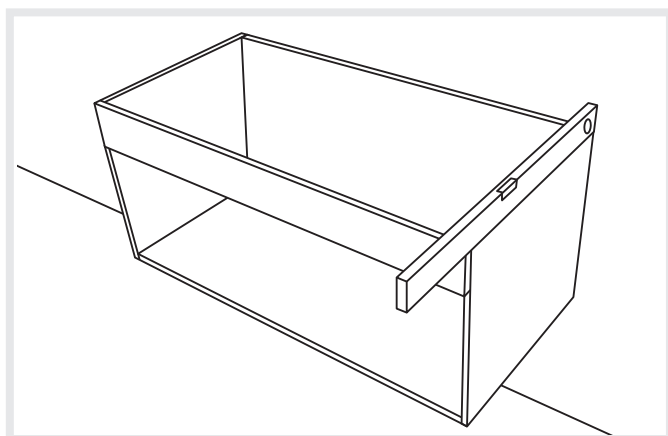

LEVEL THE VANITY

Note: Floor standing vanities should likewise, be checked for sitting level, plumb and square and suitably packed to achieve this. Fix to the wall through L bracket installed on cabinet and then ensure solid fixing along the upper back.

Note: The Frank vanity has a full height back. For installation it must be secured through the L bracket with the supplied screw.

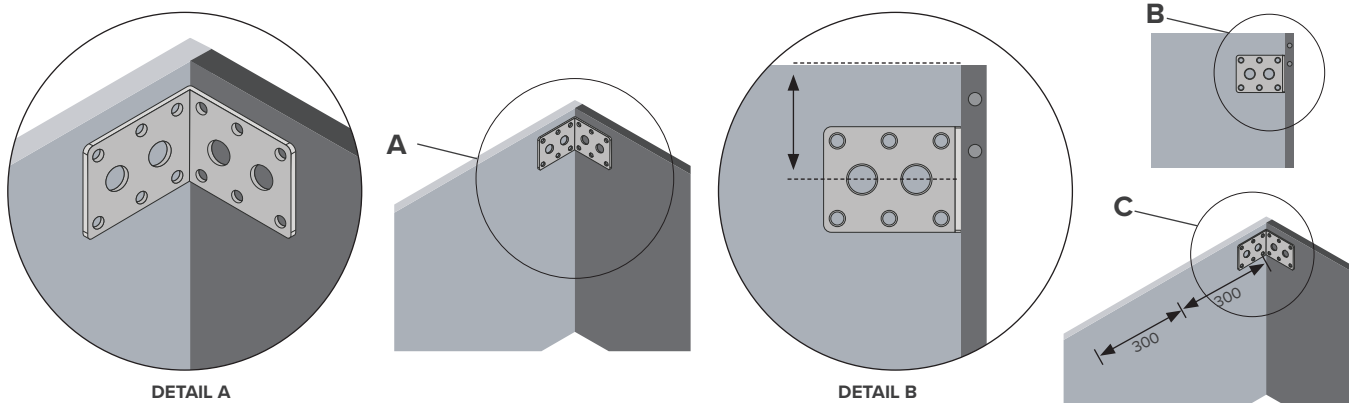

SECURE THE CABINET

Cabinet Mounting Brackets require solid fixing (145 x 45mm) behind the wall surface. It must be capable of anchoring 35mm length with a 12g Screw Thread centred 75mm down from the proposed top of cabinet height (see detail B). **Note:** The Frank vanity has a full height back, installation requires a screw through the L bracket provided on the vanity. The vanity basin top will sit above this height). Each bracket supports up to 100kg. **NOTE: Cabinets require additional fixing points evenly spaced at 300mm along the top back edge of back (see detail C).**

Vanity Unit Installation Continued...

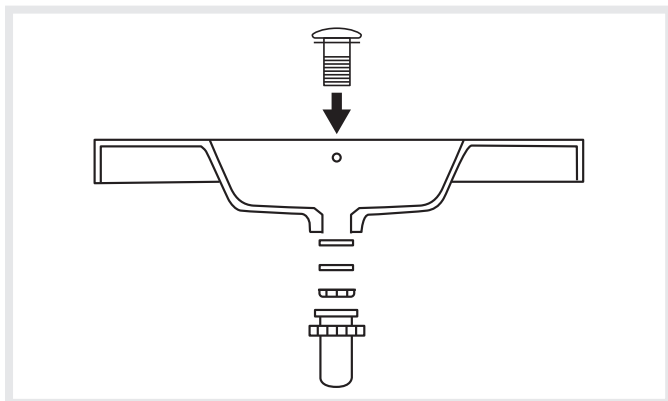

FITTING THE WASTE

When installing a waste, be wary not to overtighten, as doing so can cause the ceramic to crack. Make sure to use appropriate waste for the basin. Basins fitted with an overflow require an overflow waste. Basins without overflow should not have overflow waste fitted, as this can cause leaking. Ensure that no excess silicone or putty is obstructing the water flow.

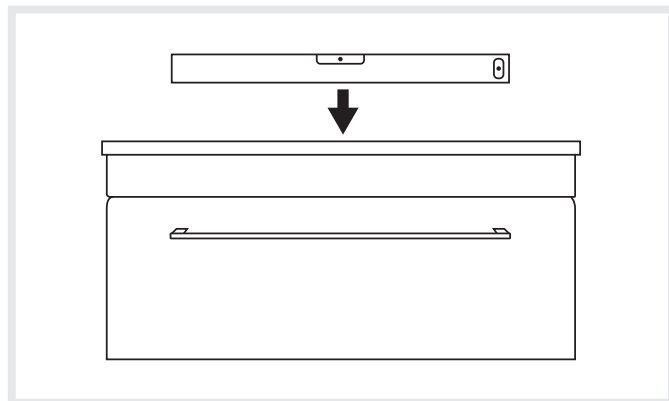

FIXING THE BASIN

Position the top so that it has an equal amount of overhang on each side and use a level to ensure the vanity top surface is level. **Note:** If the vanity is being installed in a corner, a packing strip is required and basin location will vary.

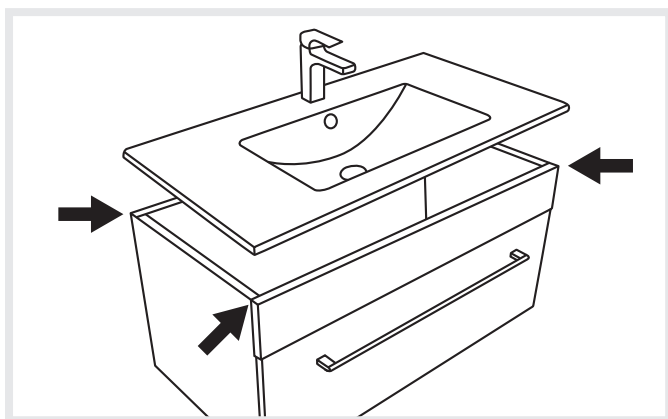

FIXING THE BASIN

Apply Silicone Sealant (not included) to all four corners of the cabinet. Place the vanity top/basin onto the cabinet. If installing a basin with wall bolt fixings - ensure basin bolts is fixed into nogs with supplied fixings as well as using a silicone sealant to the top edge of the cabinet.

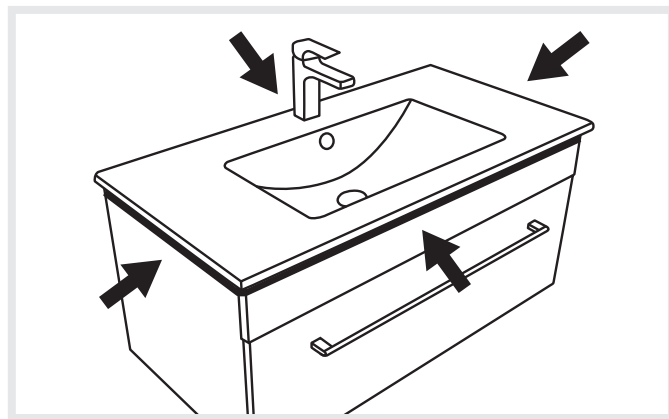

SEAL

Apply silicone on the seam between the edge of the vanity top and the wall, smooth the bead, and allow to cure before use. Materials used for the construction of this unit are water resistant and not waterproof. A fine bead of sealant (specifically formulated for bathrooms) must be used to seal edges where water penetration can occur i.e. Between the basin and the cabinet and between the wall and floor of the cabinet.

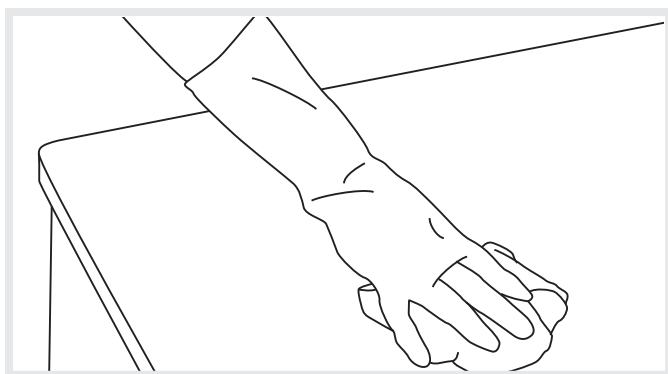

CLEAN

Clean away all building residue from the cabinet. Take care to dry any spillage or leakage of water on or inside the cabinet during installation. **Note:** Ensure drawer runners are free of building residue as this may effect the operation.

INSTALLATION NOTE

During the installation of larger vanities ie. 1200 & 1500mm wide, please ensure the top rail is straight. To ensure this stays straight and secure please use a small amount of glue/silicone to secure the basin during installation.

Hinge Adjustments

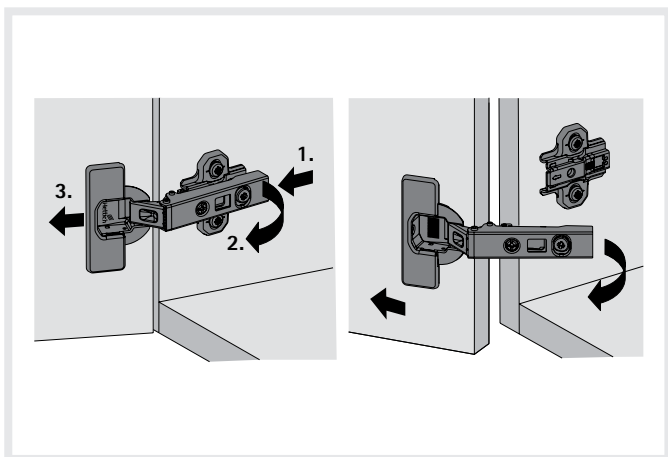

HINGE REMOVAL

To remove the door hinge lift the catch at back of hinge (1), lift body off hinge plate (2) and slide body of hinge forward (3).

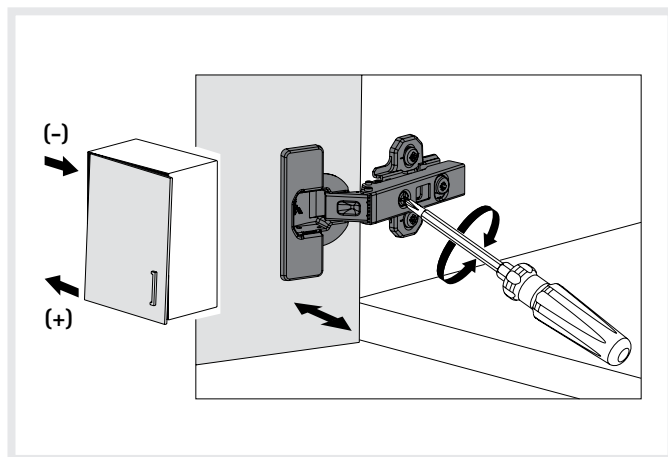

HINGE OVERLAY ADJUSTMENT

To adjust the door horizontally, using a screwdriver (as pictured) turning clockwise or anti-clockwise until alignment is straight.

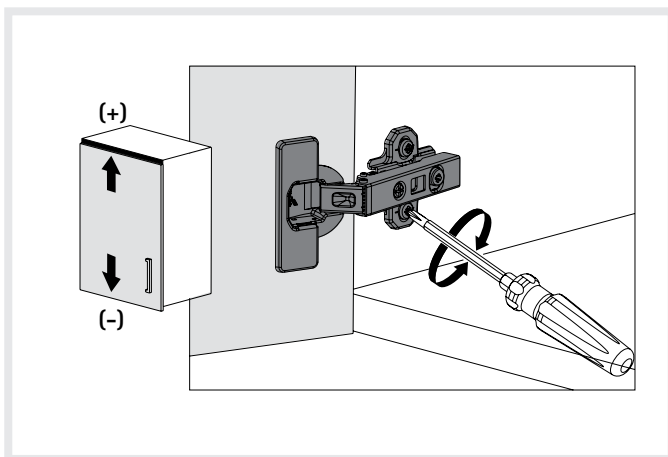

DOOR HINGE HEIGHT ADJUSTMENT

To adjust the height of the door release both hinge plate retaining screws (anti-clockwise), slide hinge plate up or down to correct position and tighten hinge plate retaining screws.

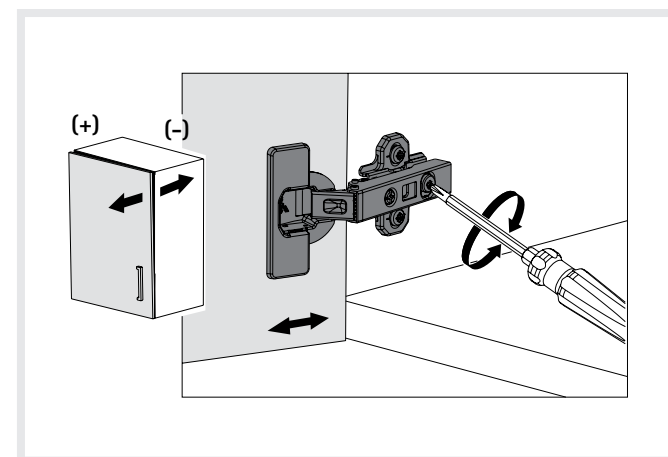

HINGE DEPTH ADJUSTMENT

To adjust the gap between the cabinet and door, using a screwdriver (as pictured) turning clockwise or anti-clockwise until alignment is straight.

Drawer Runner Adjustments

PLEASE NOTE: FRANK VANITIES HAVE PARTIAL EXTENSION RUNNERS NOT FULL EXTENSION

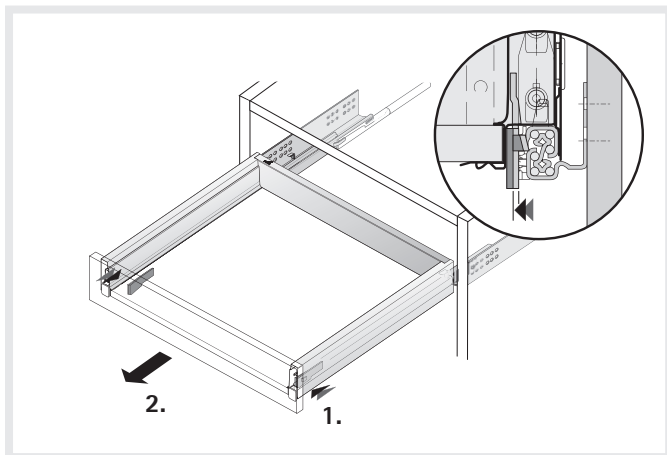

REMOVING DRAWER

Open the drawer fully. Press the grey levers inward located under the drawer and pull the drawer forward with both hands place either side of the drawer.

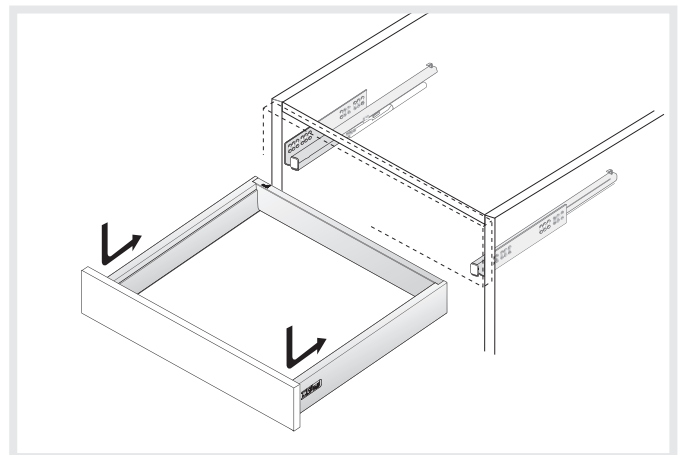

INSERTING DRAWERS

With the drawer runners fully retracted, place the drawer back onto the runners, push closed and listen for a double click and push closed.

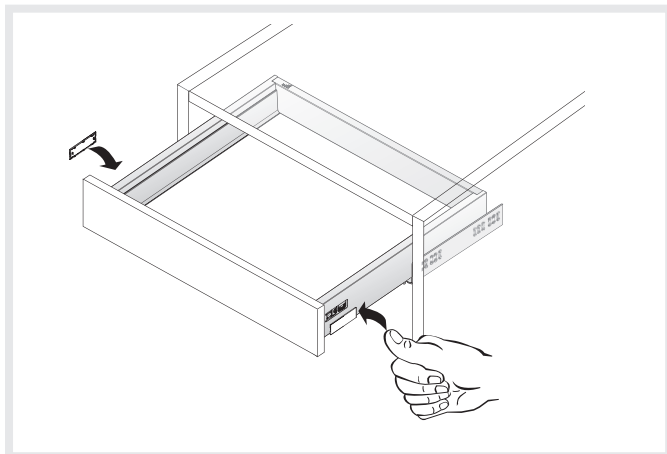

INSTALLING & REMOVING COVER CAP

Extend the drawer out and either pull the cap off or push back on.

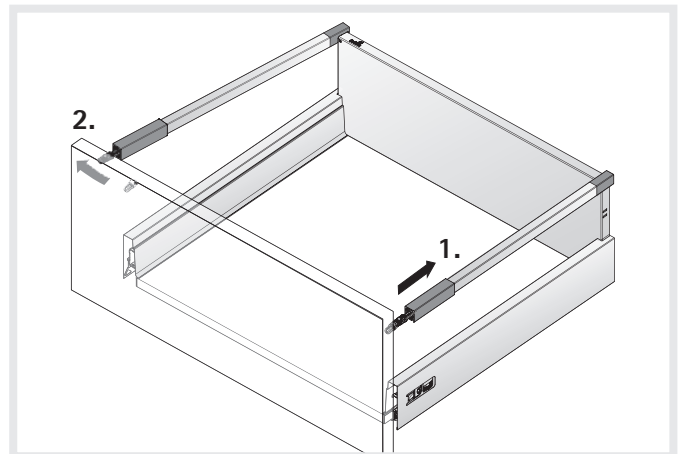

REMOVING GALLERY RAILS

To remove the gallery rails, slide the white tabs (1) towards the back of the drawer, the gallery rail will lift out of front connector.

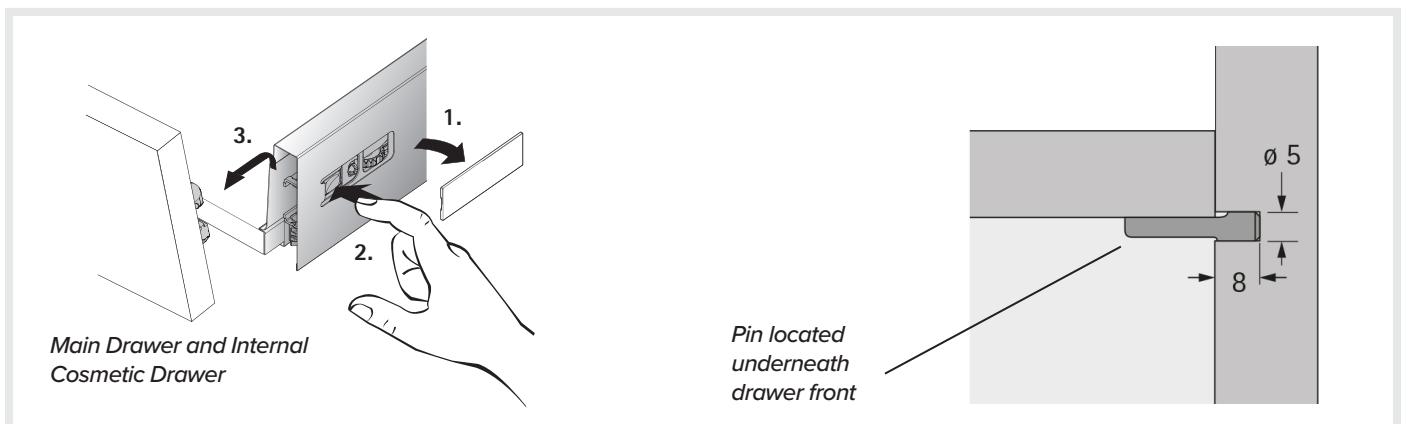

REMOVING DRAWER FRONT

To remove the front panel extend the drawer and remove the cover cap. Disconnect the gallery rails and remove the pin located underneath the drawer front. The pin is removed by pressing lightly on the base of the drawer. Once removed, push the blue button, then the drawer front can be released and lifted out.

NOTE: The drawer runner adjustments apply to all cabinetry drawers, including the internal cosmetic drawer.

Drawer Runner Adjustments continued ...

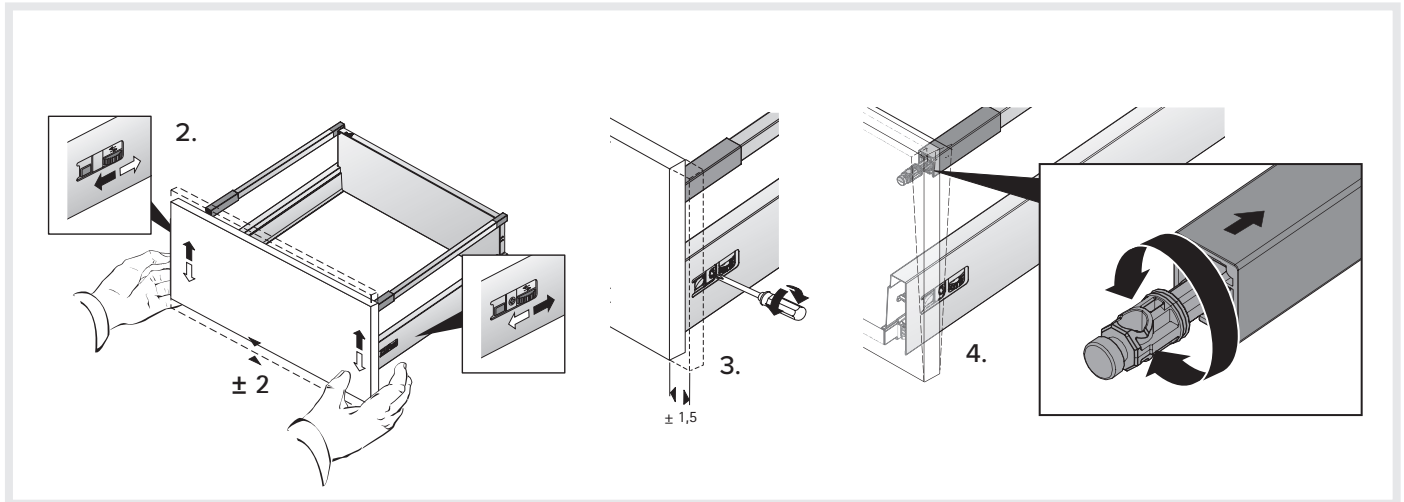

ADJUSTING FRONT PANELS (DRAWER FRONTS)

1. Remove the plastic covers on the side.
2. To make adjustments up or down use the little cogged wheels to turn each side as above.
3. To make adjustments left and right use a screwdriver to adjust the screw on the right hand drawer side as above.
4. To make adjustments in and out slide the square gallery rail cover back and use a screwdriver to turn the gallery rail adjuster as above.

Troubleshooting

PROBLEM	LIKELY CAUSE	SOLUTION
I have noticed damage on my product - should I install it?		No - please contact the merchant you purchased it through.
I can't find dimensions & specifications for my vanity unit?		Find all our cabinet specifications at: www.newtech.co.nz
My basin has limescale marks - how do I get rid of them?	Local water supply and/or basin has not been regularly cleaned	We recommend regular cleaning to avoid limescale build up. You can use a solution of vinegar and water to remove limescale.
How do I go about processing a service request?		Refer to warranty information over the page.
I need some spare parts for my product. How do I get them?		Contact the merchant you purchased your product through or check the 'Spare parts re-order list' on the resources page of the Newtech website.
My softclose drawer is not closing properly	Incorrect installation or an obstruction is preventing the drawer from closing	<ul style="list-style-type: none"> • Check that there is nothing obstructing the drawer such as plumbing or a tap hose • Check that the drawer box has been installed correctly • Check that the cabinet is installed correctly i.e. level & wall is plumb and consult your installer.
I'm not sure what I should clean my basin and cabinet with.		Mild detergent and warm water. See page 9 for basin & cabinet care tips.

Product Care

Newtech products are produced from materials that are well suited to the bathroom. Our vanities are designed to be water resistant, not water proof. It is important that your bathroom is adequately ventilated to eliminate moisture build up. High humidity will lead to permanent dampness and mould resulting in a deterioration of the materials in your bathroom. Please ensure care is taken that vanities are not exposed to large amounts or continuous water as this can lead to damage and is not covered under our Warranty on page 10.

VANITY INSET BASINS - STONECAST & VITREOUS CHINA



Newtech vanity tops and basins are manufactured from the finest materials and when treated with care will last for many years. Do not subject the basin or vanity top to water at a temperature above 55°C. Keep high heat away from the vanity top or wash basin and avoid metal or other sharp objects which could scratch and damage the surface. A simple wipe over with a damp cloth after use is all that is required. If you need to use household cleaners do not use strong citrus-based cleaners, abrasive cleaners, chemicals, disinfectants, acetone, alcohol or cleaners that incorporate isopropyl alcohol. Carefully read the cleaner product label to ensure the cleaner is safe for use on the material. The use of cleaners containing harmful ingredients (as identified above) will void Newtech's warranty.

Lime scale marks may be reduced by regular cleaning of the washbasin. *Handy Tip – Stubborn lime scale marks can normally be removed using a solution of vinegar and water.

Ceramic Tops - Newtech Vitreous China Basins are hand crafted and fired at high temperatures, which can lead to visual imperfections and distortions. This all being part of the vitreous china experience, a 5mm tolerance is considered an acceptable quality definition of conformity.

StoneCast Tops - Our composite StoneCast basins and slab tops are constructed by combining natural minerals with high performance resins creating an increased resistance. StoneCast products are moulded into precise designs creating clean, straight lines and edges with no natural imperfections.



CABINETRY, HETTICH HARDWARE, HANDLES & ACCESSORIES

Our products are manufactured from high quality materials in an easy to clean laminate finish (Vista Range). All materials used are water resistant but not waterproof unless stated.

All water spillages, leaks or flooding in or around the cabinet must be sponged off and dried immediately - this includes condensation. Keep heat away from the vanity and avoid metal or other sharp objects that could damage or scratch the surfaces. Do not use abrasive cleaning agents which contain ammonia, bleach or other strong solvents. We also advise against the use of furniture polish, acetone, ethanol, benzene and coarse cleaning sponges. Carefully read the cleaner product label to ensure the cleaner is safe for use on the material.

For regular cleaning, we recommend cleaning with a soft cloth, wrung in hot water with a mild all-purpose cleaning agent.

Warranty Information

VANITIES



Cabinetry & Panels Laminate
Finish MRB
5 Years

Hettich Soft Close
Drawer Runners,
Cupboard
Drawer & Door
Hinges
Lifetime

BASINS



Vitreous
China
basins
10 Years

StoneCast or
Composite
basins
5 Years

ACCESSORIES



Chrome, Matte Black,
Brushed Nickel, Gunmetal,
Brushed Brass, Brushed
Copper & Matte White
Accessories & Handles
5 Years

Evoke Pop-up
Basin & Bath
Wastes
1 Year

This extended warranty only covers Newtech bathroomware products, and will not extend to products which you have selected outside our product range. This extended warranty only applies to defects which have arisen solely from faulty materials or workmanship in the Products and does not apply to other defects which may have arisen as a result of, without limitation, the following: accidental damage, abuse, misuse, maltreatment, abnormal stress or strain, harsh or adverse weather conditions, including excessive water pressure or temperature, or neglect of any kind of the Products.

As per the Building Code Compliance documentation, the maximum temperature sanitary wear can be subjected to is 55 deg C. Any warranty assessment where the temperature of water for sanitary wear is above 55 deg C will be declined. The tempering valve must be subject to and comply with NZS4617 or AS1357.2

Alterations and repairs of the Products other than by a Newtech pre-approved service person are not covered. For the avoidance of doubt, attachment of accessories or use of non-genuine replacement parts other than those manufactured or approved by Newtech are not covered by this extended warranty. This extended warranty for the products commences from date of purchase or for new buildings on the date of handover for the relevant period set out in the warranty period. In addition to this extended warranty, certain legislation may give you certain rights which cannot be excluded, restricted or modified. This extended warranty must be read subject to such legislation and nothing in this warranty has the effect of excluding, restricting or modifying those rights. Newtech warranty periods have changed over time so

HOW TO MAKE A CLAIM

Please contact the merchant the product/s were purchased through and they will be able to lodge a claim with Newtech on your behalf. Once we receive the claim we will review it and may contact you for further information. Once we have assessed the claim and determined that it is the result of a defect covered by the warranty, we will arrange for the repair, replacement or refund that we determine to be the best solution.

Please also be aware that if once we visit the site to investigate or repair the product and find that it is not in fact a defect or product fault and therefore not covered by this warranty, that we may charge for the time and travel incurred.

dependent on when you purchased your product the warranty period may be different to what is stated in this publication.

To make a warranty claim, the following documentation must be emailed or faxed to Newtech:

- Name/model of product and photographs of the issue, if available;
- Proof of installation by a licensed plumber and/or proof of purchase;
- Your contact details; name, address and best contact phone number;
- Handover documentation for new homes.

Consequential loss to the extent permitted by law Newtech will not be liable for any loss or damage to furniture, floor coverings, walls, fixtures or any other consequential loss of any kind caused by any defect in the products or components.

Warranty certificate or equivalent documentation must be supplied for warranty claims to be considered. If the cost of returning any defective parts is unreasonable, please contact Newtech so that if appropriate, we can arrange a collection.

Newtech Bathroomware

Head Office: 30 Mill Road, Whanganui

Showroom: 525 Great South Road, Penrose, Auckland

Phone: 0800 728 662

Email: sales@newtech.co.nz

TO THE INSTALLER

Newtech recommends that a qualified tradesperson install this product and that it is installed to a professional standard. Please inspect for damage before installation. It is the responsibility of the installer to make any adjustments to cabinetry doors and drawers after installation if required.

If there is damage to the product on freight arrival please immediately contact the merchant the product/s were purchased through and they will lodge a claim with Newtech.

Installers need to know that under the Consumer Guarantees Act (CGA) they are responsible for any product they supply AND/OR install.

Product Code:

Product Name:

Date Purchased:

Purchased from:

Installed by:

VISIT OUR WEBSITE

WWW.NEWTECH.CO.NZ

Visit our website to view and download specification sheets, brochures, flyers, installation guides, product care manuals, watch 'how to videos' and much more.

VISIT OUR YOUTUBE CHANNEL

NEWTECH.CO.NZ/YOUTUBE

Videos about Newtech and our products are available on our YouTube channel as well as our website.

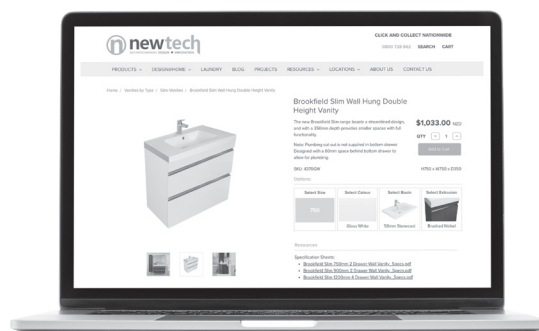

HEAD OFFICE & DISTRIBUTION

30 Mill Road, Whanganui, 0800 728 662, sales@newtech.co.nz

CONCEPT SHOWROOM

525 Great South Road, Penrose, Auckland, 09 930 6200
aucklandshowroom@newtech.co.nz

