

SPECIFICATION SHEET

Sahara Luxe 900mm 2 Drawers Right Hand Offset Basin Wall Vanity

Code: 10282R



Features

- 2 Drawers Double Tier Wall Hung
- Cabinet with Extrusion
- Right Hand Offset Basin with Slab Top
- Melamine laminate on moisture resistant board
- Dimensions: H650 x W900 x D453
- Designed & Assembled in NZ

*Note: Vessel basins are purchased separately.
Visit www.newtech.co.nz for the full range of vessel basin options.*

Technical Details

Note: All measurements shown are in millimetres. Sizes are nominal.

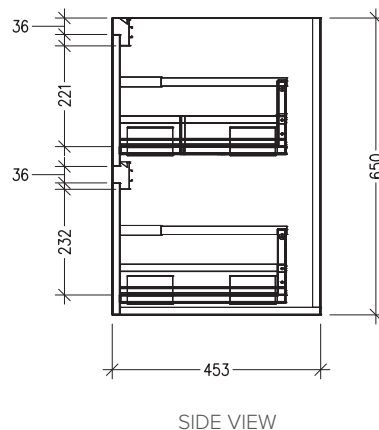
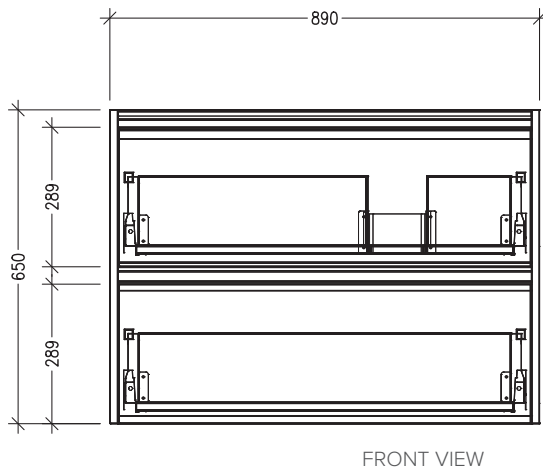
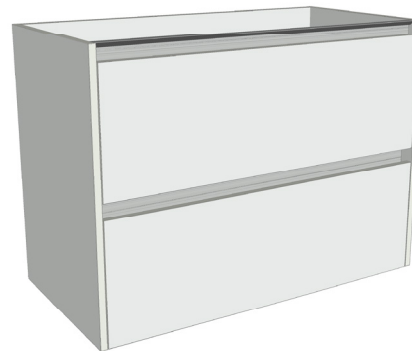
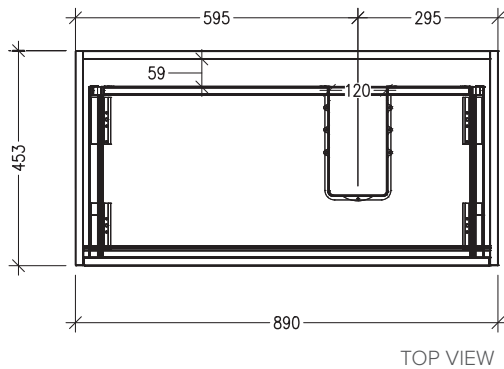

SPECIFICATION SHEET

Sahara Luxe 900mm 2 Drawers Right Hand Offset Basin Wall Vanity

Code: 10282R



Features

- 2 Drawers Double Tier Wall Hung
- Cabinet with Handle
- Right Hand Offset Basin with Slab Top
- Melamine laminate on moisture resistant board
- Dimensions: H650 x W900 x D453
- Designed & Assembled in NZ

*Note: Vessel basins are purchased separately.
Visit www.newtech.co.nz for the full range of vessel basin options.*

Technical Details

Note: All measurements shown are in millimetres. Sizes are nominal.

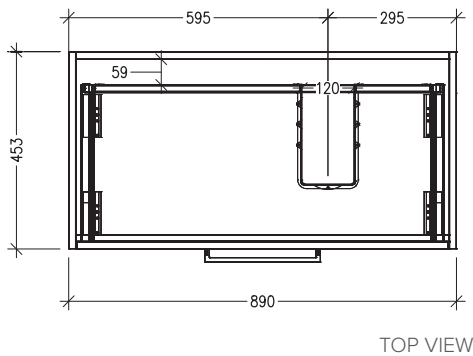

TOP VIEW

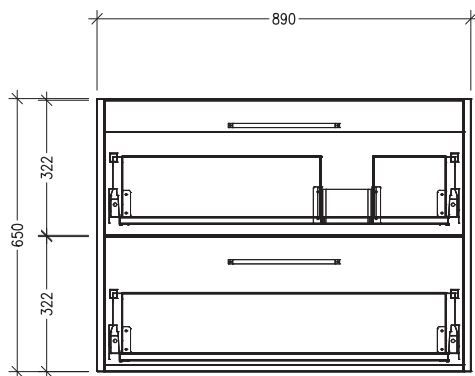

FRONT VIEW

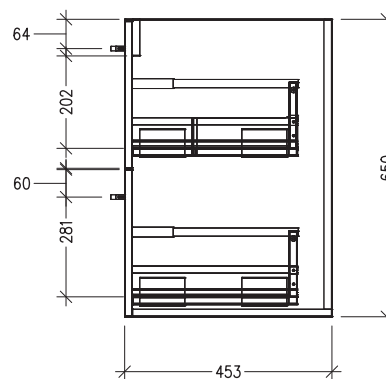

SIDE VIEW

SPECIFICATION SHEET

Sahara Luxe 900mm 2 Drawers Right Hand Offset Basin Wall Vanity

Code: 10282R



Features

- 2 Drawers Double Tier Wall Hung
- Cabinet with Negative Timber Detail
- Right Hand Offset Basin with Slab Top
- Melamine laminate on moisture resistant board
- Dimensions: H650 x W900 x D453
- Designed & Assembled in NZ

*Note: Vessel basins are purchased separately.
Visit www.newtech.co.nz for the full range of vessel basin options.*

Technical Details

Note: All measurements shown are in millimetres. Sizes are nominal.

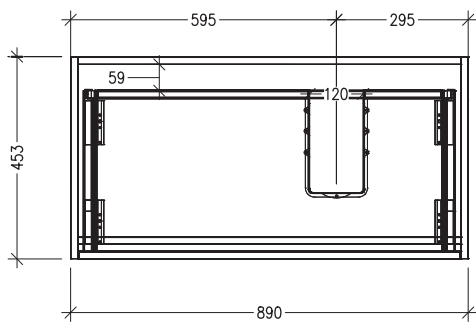

TOP VIEW

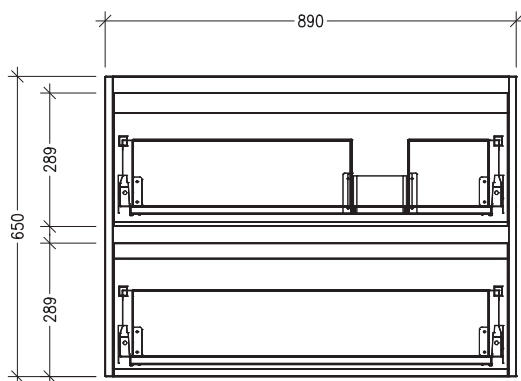
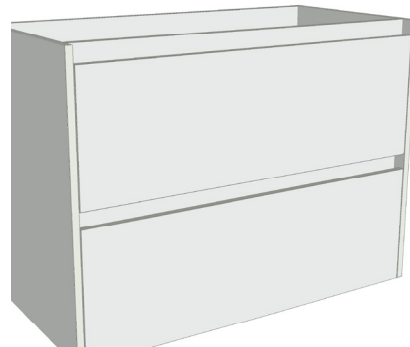

FRONT VIEW

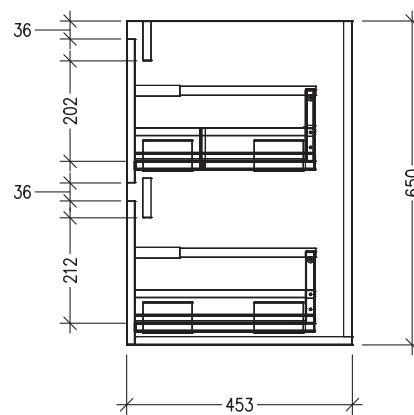

SIDE VIEW