

SPECIFICATION SHEET

Sahara 1500mm 2 Drawers Wall Vanity

Code: 10166



Features

- 2 Drawers Wall Hung
- Cabinet with Extrusion
- Centre Basin
- Dimensions: H400 x W1500 x D453
- Designed & Assembled in NZ

Technical Details

Note: All measurements shown are in millimetres. Sizes are nominal.

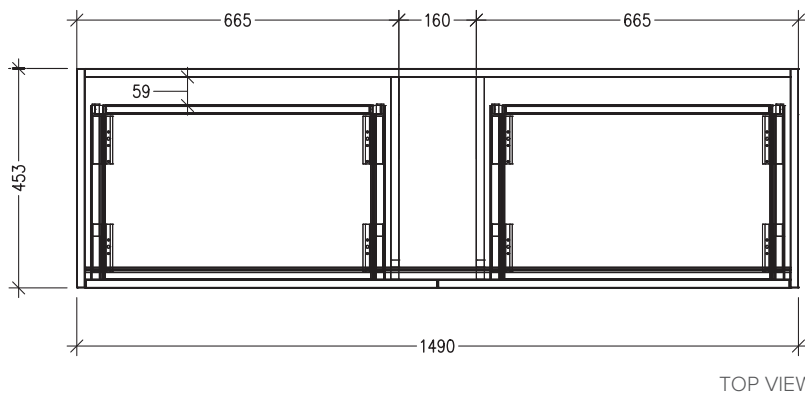

TOP VIEW

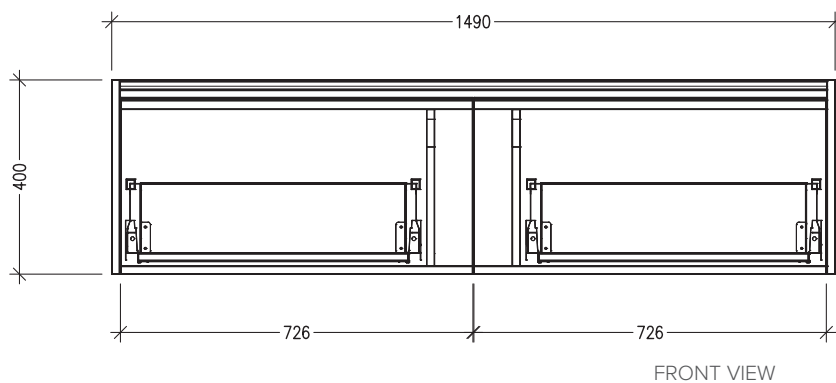
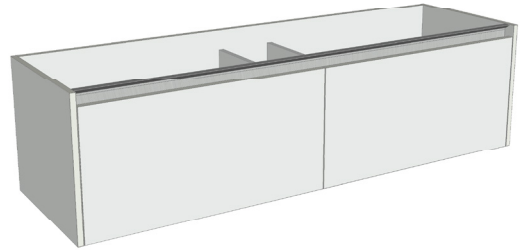

FRONT VIEW

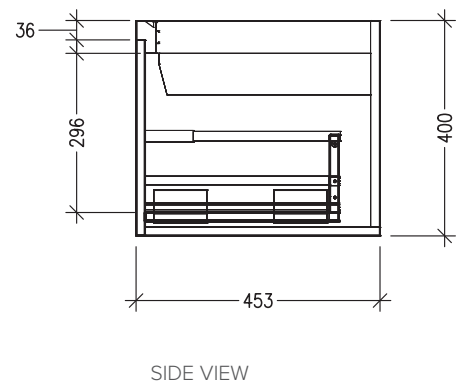

SIDE VIEW

SPECIFICATION SHEET

Sahara 1500mm 2 Drawers Wall Vanity

Code: 10166



Features

- 2 Drawers Wall Hung
- Cabinet with Handle
- Centre Basin
- Dimensions: H400 x W1500 x D453
- Designed & Assembled in NZ

Technical Details

Note: All measurements shown are in millimetres. Sizes are nominal.

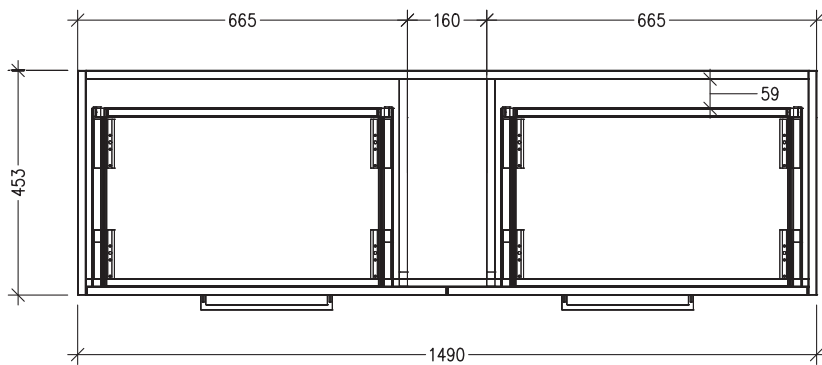

TOP VIEW

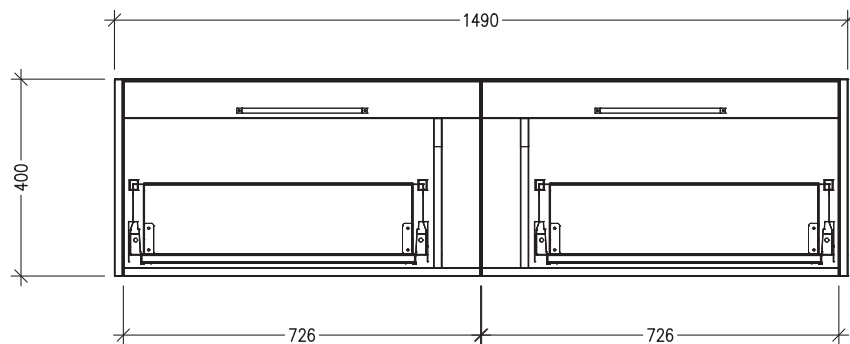
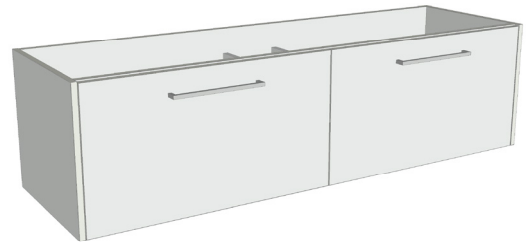

FRONT VIEW

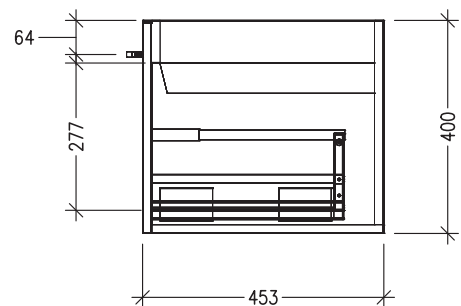

SIDE VIEW

SPECIFICATION SHEET

Sahara 1500mm 2 Drawers Wall Vanity

Code: 10166



Features

- 2 Drawers Wall Hung
- Cabinet with Negative Timber Detail
- Centre Basin
- Dimensions: H400 x W1500 x D453
- Designed & Assembled in NZ

Technical Details

Note: All measurements shown are in millimetres. Sizes are nominal.

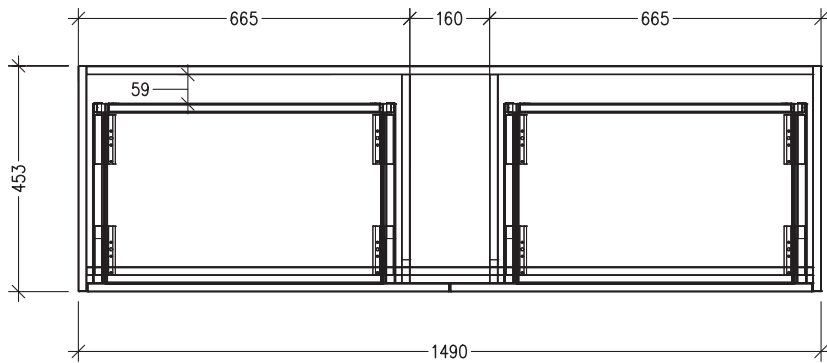

TOP VIEW

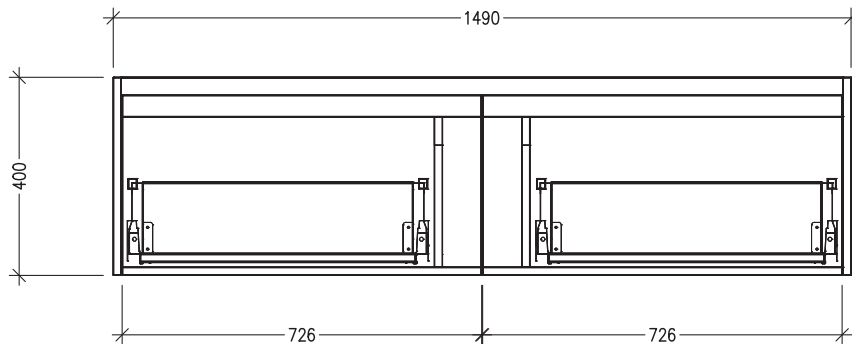
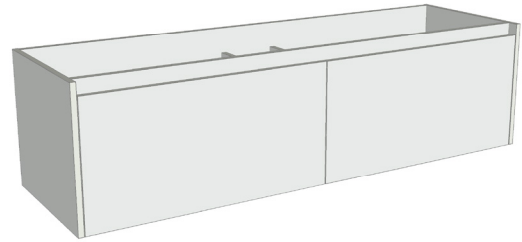

FRONT VIEW

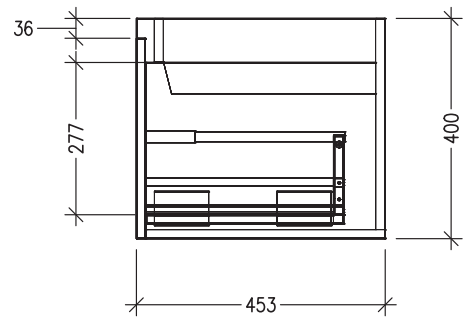

SIDE VIEW