

# SPECIFICATION SHEET

## Porscha Slim 1200 2-Drawer Single Basin Wall Hung Vanity



### Features

- 2-Drawer Wall Hung Vanity with Designer Drawer Fronts
- StoneCast 50mm Basin
- Full Extension Soft Close Drawers with Extrusions - *Extrusion upgrade options available*
- Designer Drawer Fronts are pre-installed on all vanities
- Dimensions: H420 x W1200 x D350

### Technical Details

Note: All measurements shown are in millimetres. Sizes are nominal.

### IMPORTANT

For installation, please ensure cabinet is fixed through middle division brackets into solid fixings.

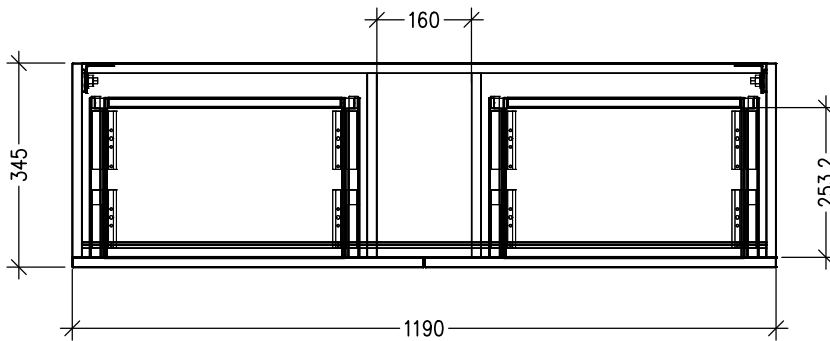

TOP VIEW

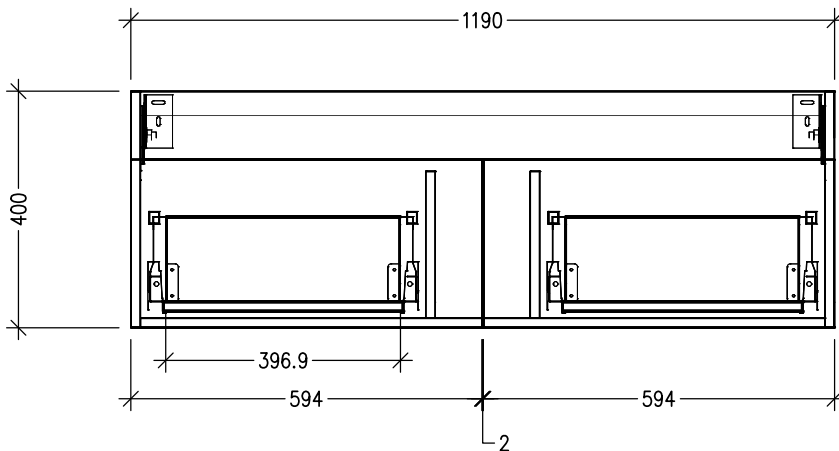

FRONT VIEW

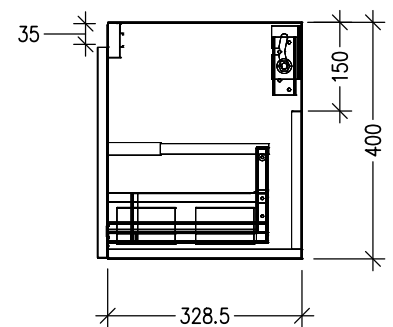

SIDE VIEW

# SPECIFICATION SHEET

## StoneCast 1200 Basin

H50 X W1200 X D350

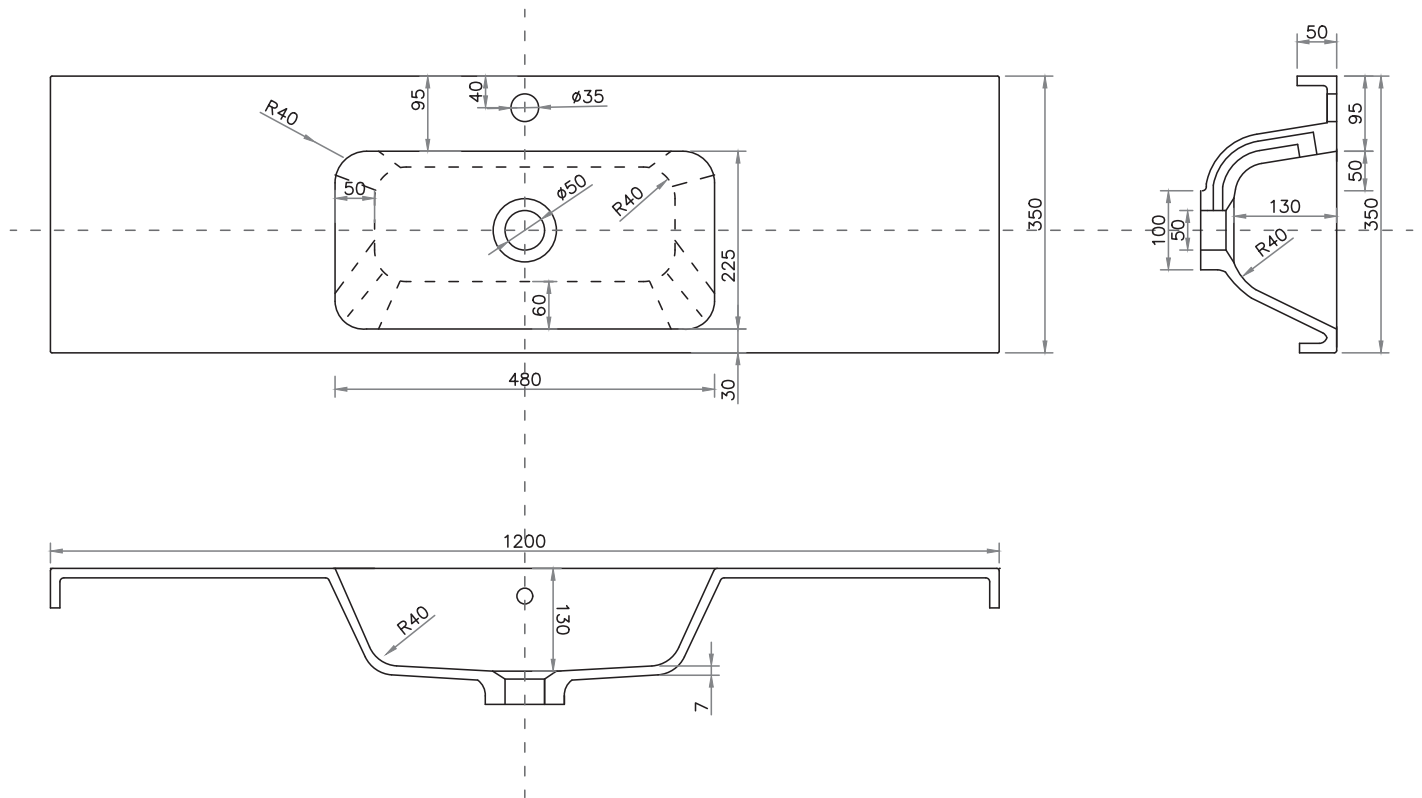

# SPECIFICATION SHEET

## Designer Drawer/Door Fronts

BARNSLEY  
18mm Inset Frame  
Code: BL

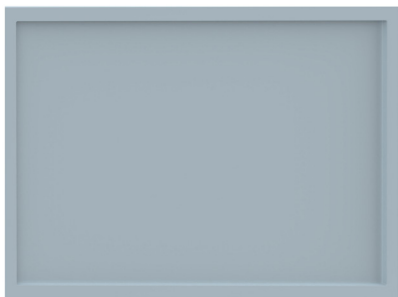

PRESTON  
60mm Inset Frame  
Code: PT

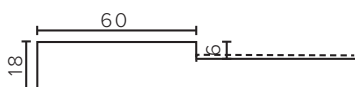
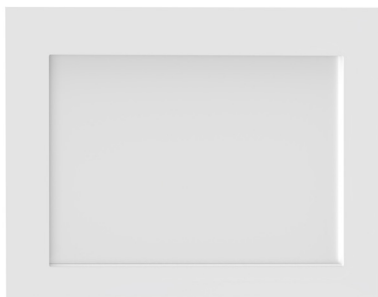

TURNBERRY  
Ripple Design  
Code: TB

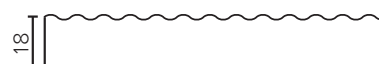

NEWPORT  
V-Groove Panels  
Code: NP

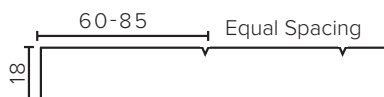

MIAMI  
Little Wave  
Code: MI

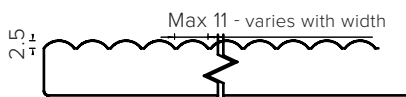
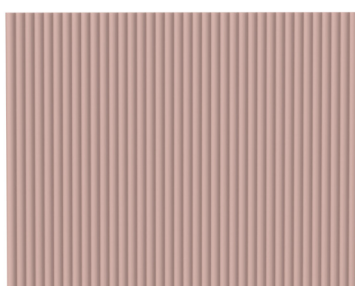

LAUREL  
Fluted Lines  
Code: LU

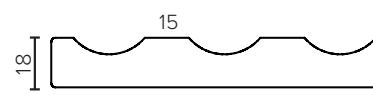

LINCOLN  
Fence Style  
Code: LN

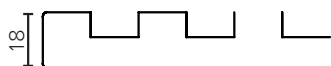
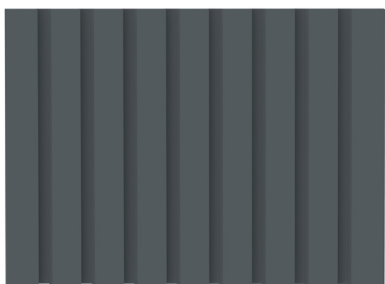

ASPEN  
Scalloped Wave  
Code: AP

