

Installation Instructions

Polo Vertical Heated Towel Rail

Newtech recommends that a registered electrician install this product and that it is installed to the current wiring regulations and in particular to those regulations that include the installation of appliances and accessories in damp environments such as bathrooms. It must be installed in accordance with relevant Australian/New Zealand Standards (AS/NZS).

SAFETY INFORMATION

This electrical appliance is intended to warm and dry towels and therefore **hot to touch**. Young children or infirm persons should be supervised to ensure that they do not play with or misuse the appliance. The towel rail has been designed to withstand the loads expected during normal operation as a towel rail. The towel rail is not a climbing pole and should not be used as such. The appliance will feel hotter to touch during Summer periods because of the rise in ambient temperature. The insulation effect of towels will cause the operating temperature to increase. The appliance is **ONLY** used for warming and drying towel, **DO NOT** use it for any other purpose.

ELECTRICAL

The Polo towel rail must be wired by a registered electrician. A mains supply (230v-240v) isolating switch must be positioned near the towel rail but out of reach from wet areas like baths and showers. A wall or ceiling cavity must be available to conceal the transformer. **Each single rail must be connected to one 12 Volt transformer** and cannot be connected directly to 240V supply. See Figure 6.0.

Only one end of the pole should be connected to the power source. The other end will need to have the wires terminated as there are 2 separate looms in the rail. See Figure 1.0 and 4b

WALL MOUNTING

The towel rail mounting spigot must be fastened to a solid fixing point, eg. timber or brickwork. The mounting face of the towel pole **must be fitted against a solid surface** eg. tiles (not suitable directly onto gib or plasterboard). Recommended location is 600mm above floor, 300mm from any permanent fixing and 250mm between poles. See Figure 1.0

SPECIFICATIONS AND DIMENSIONS

Model	Colour	Dimensions	Wattage
P1100	Chrome	H1100 x W50 x D132	40W
P1100NK	Brushed Nickel	H1100 x W50 x D132	40W
P1100MW	Matte White	H1100 x W50 x D132	47W
P1100BB	Brushed Brass	H1100 x W50 x D132	40W
P1100CP	Brushed Copper	H1100 x W50 x D132	40W
P1100GM	Gunmetal	H1100 x W50 x D132	40W
P1100MB	Matte Black	H1100 x W50 x D132	47W

Newtech recommends the Polo rail uses 12 Volts AC electronic transformer. 1 x 40W or 47W rail to be used with 1 x LT050 (35w-70w) Transformer only.

WARNING

The Polo vertical rail has a small footprint against the wall and secureness should be periodically checked. The Allen Key securing the rail may require tightening especially during the settling period. The cable holes and fixing holes must be neatly and accurately drilled. For drilling through hard surfaces eg. porcelain tiles, marble or granite etc, a diamond core drill must be used. Ensure final rail position will conceal wiring hole.

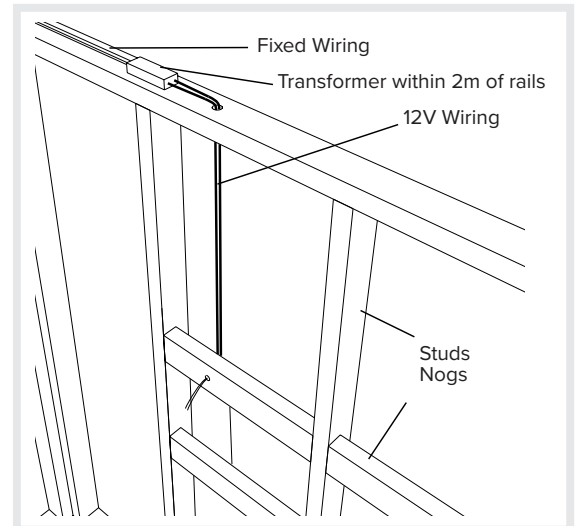

Figure 1.0

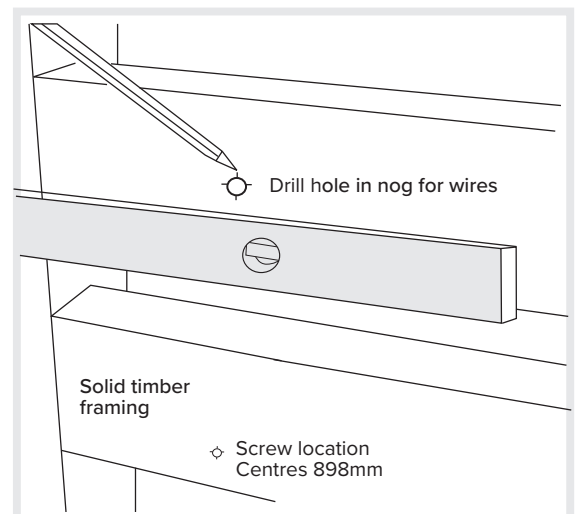

Figure 2.0

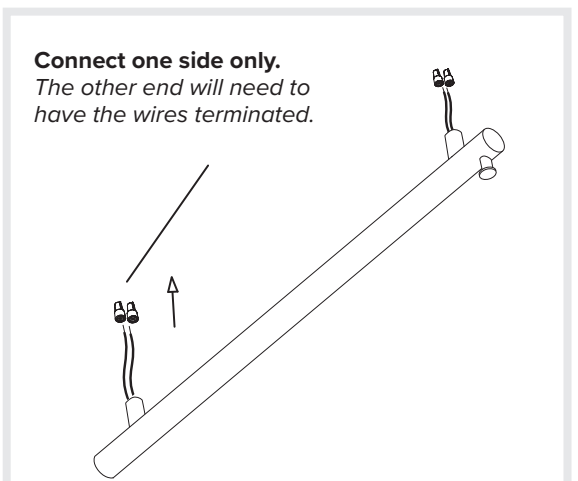

Figure 3.0

Installation Instructions

Polo Vertical Heated Towel Rail

INSTALLATION

- Typical wiring for timber framed walls is shown in *Figure 1.0*
- The distance from the transformer to the furthest 12V connection should be no more than 2 metres of 12V cabling.
- Make sure that the 12V cabling doesn't cross the 230V mains cable.
- Ceiling or Wall Insulation should be removed from the vicinity of the transformer to a minimum radius of 150mm.

BEFORE LINING

- Refer to figure 1.0. Run your wires through the wall as required. Make sure your wires are preinstalled outside your nog where you intend your rail to be installed.
- Use a level to make sure that these holes are plumb. See *Figure 2.0*
- The recommended horizontal distance between rails is 250mm.
- Wire requires threading through the 9mm spigot hole and leaving till after gib/tile for installation of rail (see *figure 1.0*) and connecting to the 12V transformer.

AFTER LINING

- Attach each leg to the Polo rail with the 4.5mm threaded screw.
- Align your spigot with your wires.
- Thread your wires through the 9mm cable spigot hole.
- Secure your spigot to the wall with provided screws.
- Take care to ensure that the rail, in its final position, will fully conceal the wiring and cable hole.
- Use a level to determine the correct position for the blocks at the non-cabled end. See *Figure 4b*
- Fix the mounting blocks at the non-cabled end.
- Connect the appliance wiring to the rail as per NZ electrical requirements.
- Make sure that there are no red and blue wires connected as this would create a short circuit.
- **DO NOT PULL THE WIRE OUT OF THE TOWEL RAIL - THIS WIRE IS CONNECTED TO THE INTERNAL HEATING CABLE. BE CAREFUL NOT TO PULL THE ELEMENT WIRES OUT - NO EXCESS FORCE SHOULD BE REQUIRED.**
- Push the towel rail onto the mounting spigots until flush with the wall.
- Fix the towel rail in position using the grub screws and allen key provided.
- Continue to fit the remaining rails using the same procedure.

CARE & CLEANING

- Do not use cream cleaner or any abrasive or corrosive cleaners.
- The heated towel rails are best wiped down from time to time with a soft clean cloth moistened with warm soapy water. Fingerprints can be removed by using a dry, soft microfibre cloth.

Disclaimer: Products in these installation instructions must by regulation be installed by a licensed and registered tradesperson. Newtech cannot be held responsible if the installation and use of the towel rails is not carried out in accordance with these instructions or for materials not supplied by Newtech. The manufacturer/distributor reserves the right to vary specifications without prior notification.

Powered leg installation

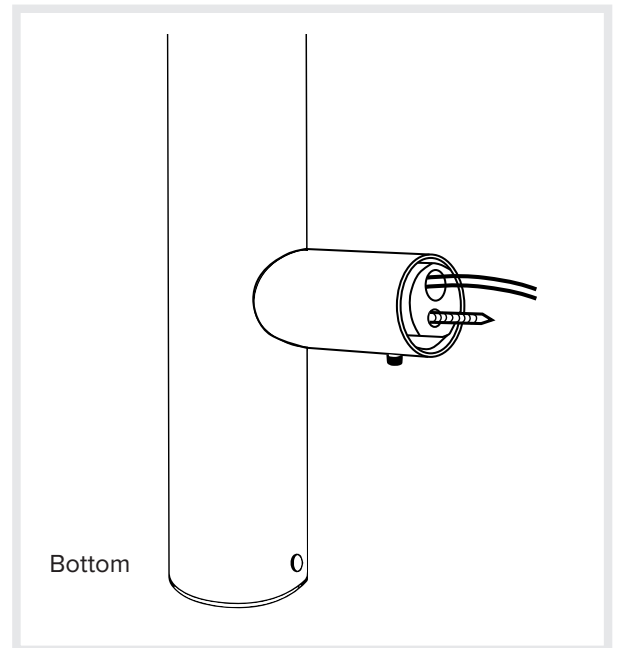

Figure 4a

Unpowered leg installation

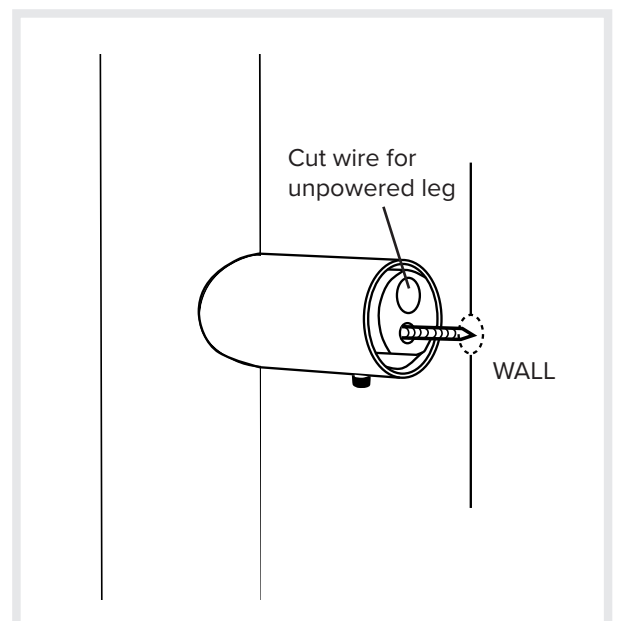

Figure 4b