

# SPECIFICATION SHEET

## Harrow 900 2-Drawer Wall Hung Vanity

Newtech Code: 4644



### Features

- 2-Drawer Wall Hung Vanity with Inset Basin
- StoneCast 20mm Via Basin [Standard] - Upgrade options available
- Full Extension Soft Close Drawers with Handle - *Handle upgrade options available*
- Dimensions: H670 x W900 x D465

See [www.newtech.co.nz](http://www.newtech.co.nz) for the full range of basin, colour and handle options.

### Technical Details

Note: All measurements shown are in millimetres. Sizes are nominal.

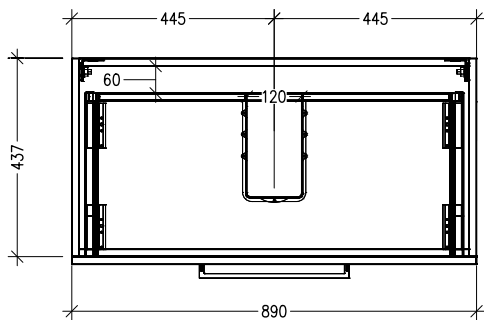

TOP VIEW

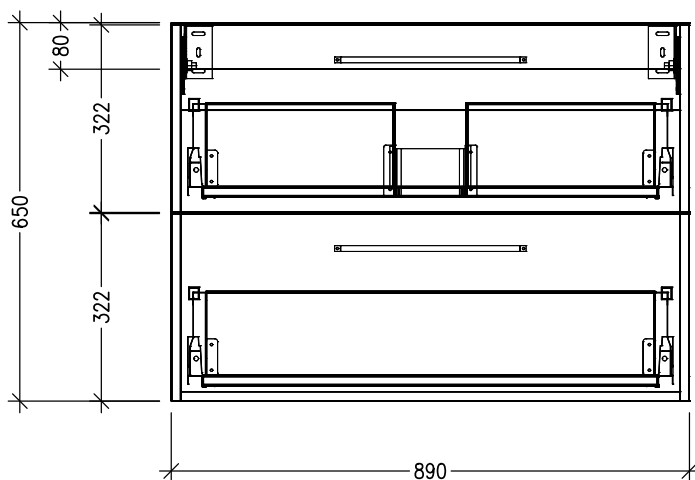

FRONT VIEW

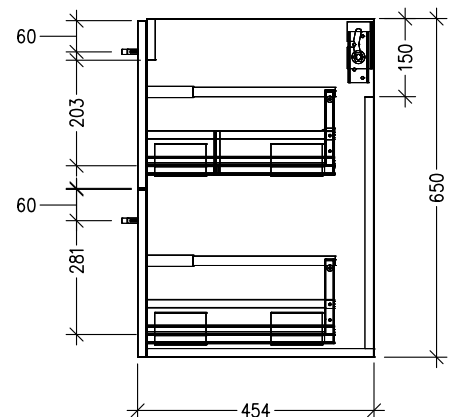

SIDE VIEW

# SPECIFICATION SHEET

## Harrow 900 2-Drawer Wall Hung Vanity with cosmetic drawers

Newtech Code: COSLR,COSL,COSR

### Technical Details

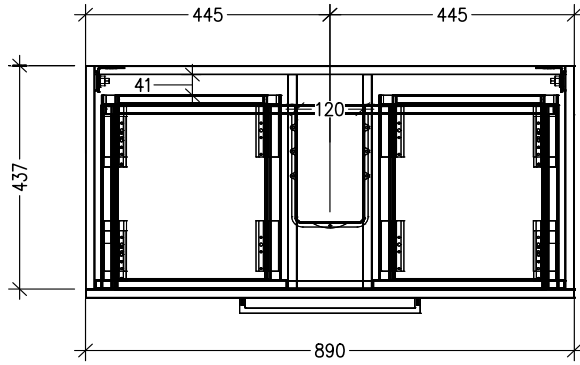

TOP VIEW

Note: Drawings shown are for COSLR. When COSL or COSR is selected please ignore the opposite cosmetic drawer in the drawings as the opposite side would be a full depth drawer.

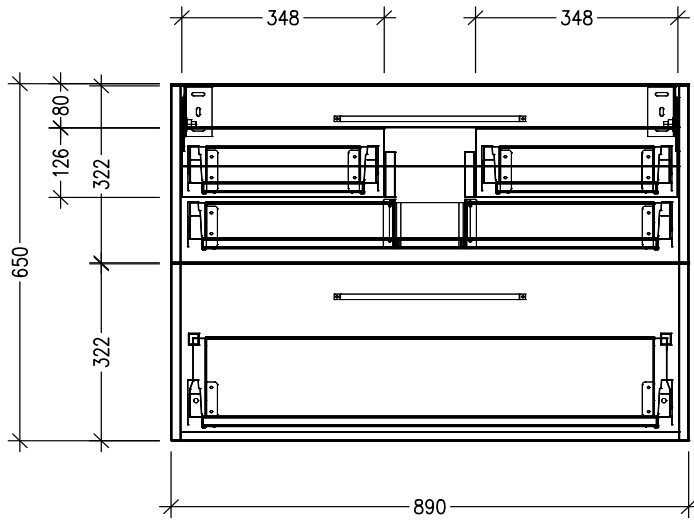

FRONT VIEW

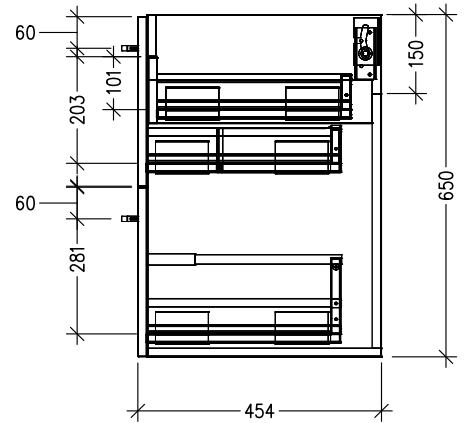

SIDE VIEW