

Installation Instructions

Freedom Heated Towel Rails

Newtech recommends that a registered electrician install this product and that it is installed to the current wiring regulations and in particular to those regulations that include the installation of appliances and accessories in damp environments such as bathrooms. It must be installed in accordance with relevant Australian/New Zealand Standards (AS/NZS).

This electrical appliance is intended to warm and dry towels and therefore **hot to touch**. Young children or infirm persons should be supervised to ensure that they do not play with or misuse the appliance. The towel rail has been designed to withstand the loads expected during normal operation as a towel rail. The towel rail is not a ladder and should not be used as such.

ELECTRICAL

The towel rail must be wired by a registered electrician. An isolating switch must be positioned near the towel rail but out of reach from wet areas like baths and showers. A wall or ceiling cavity must be available to conceal the transformer. All **rails must be connected to the 12 Volt transformer in parallel** and cannot be connected directly to 240V supply. See Figure 6.0

WALL MOUNTING

The towel rail mounting spigot must be fastened to a solid fixing point, eg. timber or brickwork. The mounting face of the towel rail **must be fitted against a solid surface** eg. tiles (not suitable directly onto gib or plasterboard). Recommended location is 600mm above floor, 300mm from any permanent fixing and 250mm between rails.

SPECIFICATIONS AND DIMENSIONS

Model	Length (mm)	Width (mm)	Depth (mm)	Wattage
SR220	632	40	100	23W
SR222	432	40	100	17W
SR224	832	40	100	30W
SR240	632	32	100	18W
SR242	432	32	100	13W
SR244	832	32	100	23W
SR230	632	40	100	23W
SR232	432	40	100	17W
SR234	832	40	100	30W

All rails use 12 Volts AC isolating transformer. Ensure the combined total wattage for freedom rails doesn't exceed transformer rating. Letters represent colour only: NK = Brushed Nickel, GM = Gunmetal, B = Matte Black, BB = Brushed Brass

WARNING

These rails have a small footprint against the wall and secureness should be periodically checked. The Allen Key securing the rail may require tightening especially during the settling period. The cable holes and fixing holes must be neatly and accurately drilled. For drilling through hard surfaces eg. porcelain tiles, marble or granite etc, a diamond core drill must be used. Ensure final rail position will conceal wiring hole.

Do not connect both left and right hand wires.

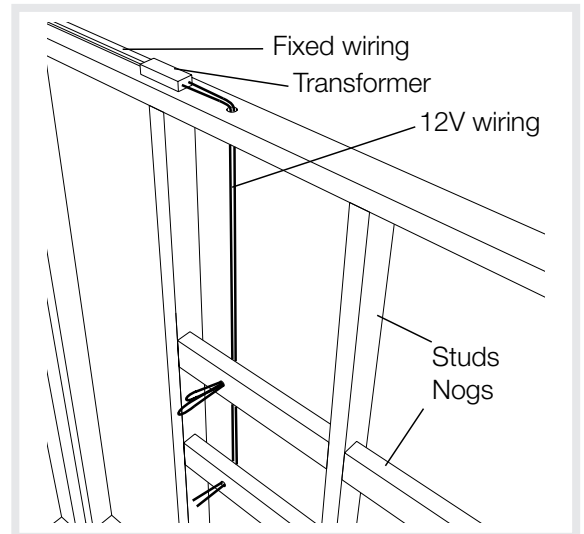

Figure 1.0

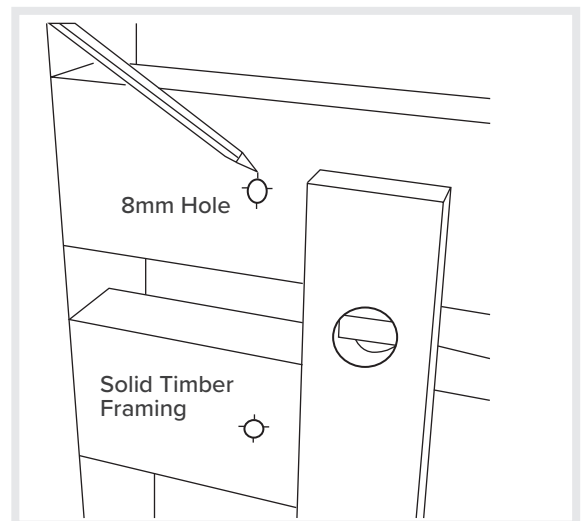
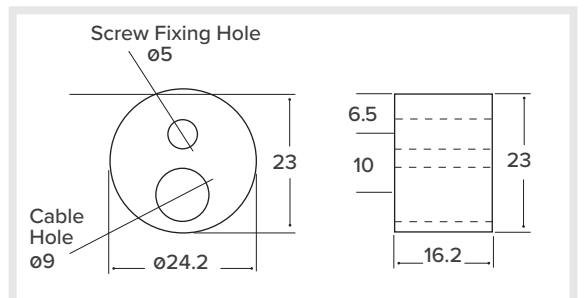
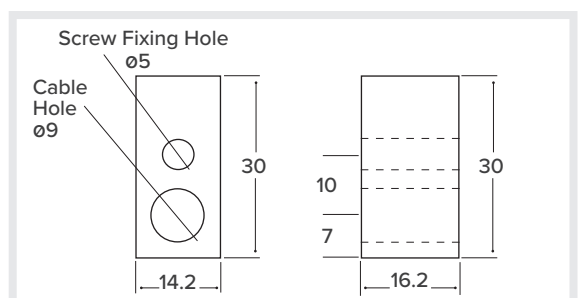

Figure 2.0



Round Mounting Block
Applies to SR242, 240, 244

Figure 3.0



Square Mounting Block
Applies to SR222, 220, 224, 230, 232, 234

Figure 3.0

Installation Instructions

Freedom Heated Towel Rails

INSTALLATION

- Typical wiring for timber framed walls is shown in *Figure 1.0*
- The distance from the transformer to the furthest 12V connection should be no more than 2000mm.
- Make sure that the 12V cabling doesn't cross the 230V mains cable.
- Insulation should be removed from the vicinity of the transformer to a radius of 150mm.
- The single bar heated towel rail is designed as dual wire option (left or right hand) - connect one side only.

BEFORE LINING

- Drill 10mm diameter holes in the wall framing first.
- Use a level to make sure that these holes are plumb. See *Figure 2.0*
- The recommended vertical distance between rails is 240mm.
- Pull the supplied appliance wire through the 10mm holes as shown in *Figure 1.0* and connect to the 12V transformer (also supplied).

AFTER LINING

- Fix the top rail first and work downwards.
- Fix the mounting blocks at the cable end first. See *Figure 3.0*.
- Take care to ensure that the rail, in its final position, will fully conceal the wiring and cable hole.
- Use a level to determine the correct position for the blocks at the non-cabled end. See *Figure 4.0*
- Fix the mounting blocks at the non-cabled end.
- Connect the appliance wiring to the towel rail element using the wire nuts provided.
- Make sure that there are no white and blue wires connected as this would create a short circuit.
- **DO NOT PULL THE WIRE OUT OF THE TOWEL RAIL - THIS WIRE IS CONNECTED TO THE INTERNAL HEATING CABLE. PULLING OUT THE WIRE WILL EXTRACT THE HEATED SEGMENT.**
- Push the towel rail onto the mounting spigots until flush with the wall.
- Fix the towel rail in position using the Allen key provided.
- Continue to fit the remaining rails using the same procedure.

CARE & CLEANING

- Do not use cream cleaners.
- Do not use any abrasive or corrosive cleaners.
- The heated towel rails are best wiped down from time to time with a damp cloth.

This installation sheet is applicable to the following SR Freedom Heated Towel Rail models, 220, 222, 224, 240, 242, 244, 230, 232, 234.

Disclaimer: Products in these installation instructions must by regulation be installed by a licensed and registered tradesperson. Newtech cannot be held responsible if the installation and use of the towel rails is not carried out in accordance with these instructions or for materials not supplied by Newtech. The manufacturer/distributor reserves the right to vary specifications without prior notification.

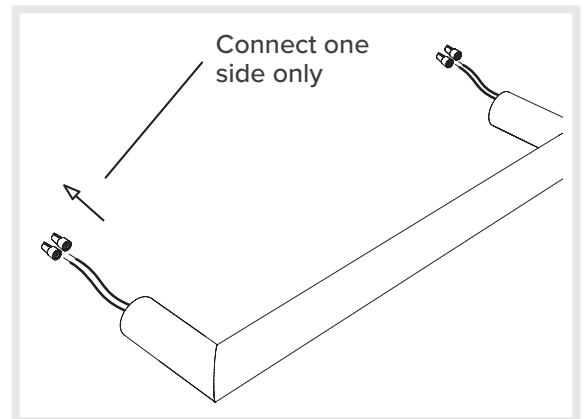

Figure 4.0

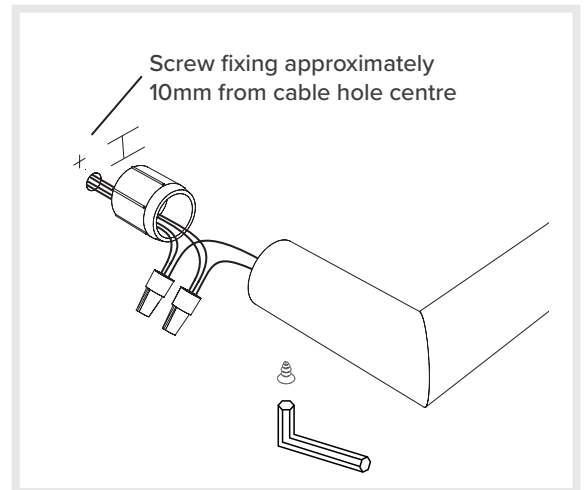

Figure 5.0

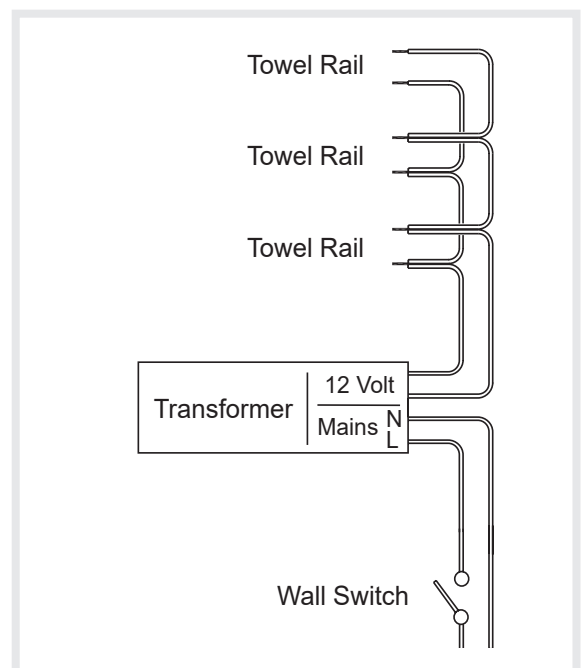

Figure 6.0