

SPECIFICATION SHEET

Francisco Slim 1200 2-Drawer Single Basin Wall Hung Vanity

Newtech Code: 5430



Features

- 2-Drawer Wall Hung Vanity with Designer Drawer Front
- StoneCast 50mm Basin
- Full Extension Soft Close Drawers with Handles - *Handle upgrade options available*
- Designer Drawer Fronts are pre-installed on all vanities
- Dimensions: H420 x W1200 x D350

Technical Details

Note: All measurements shown are in millimetres. Sizes are nominal.

IMPORTANT

For installation, please ensure cabinet is fixed through middle division brackets into solid fixings.

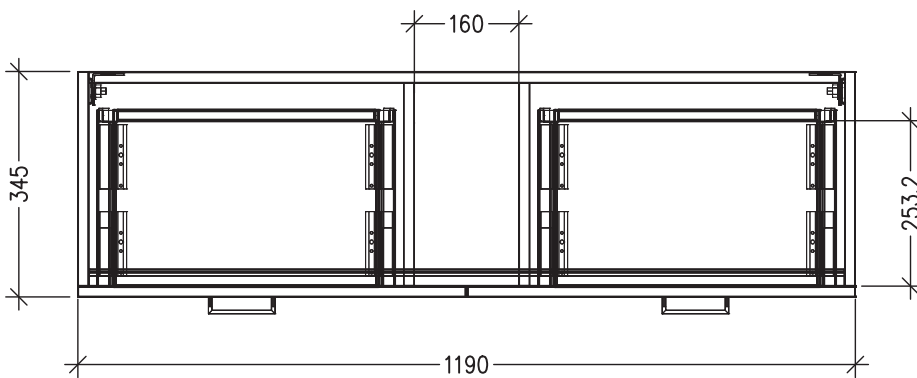

TOP VIEW

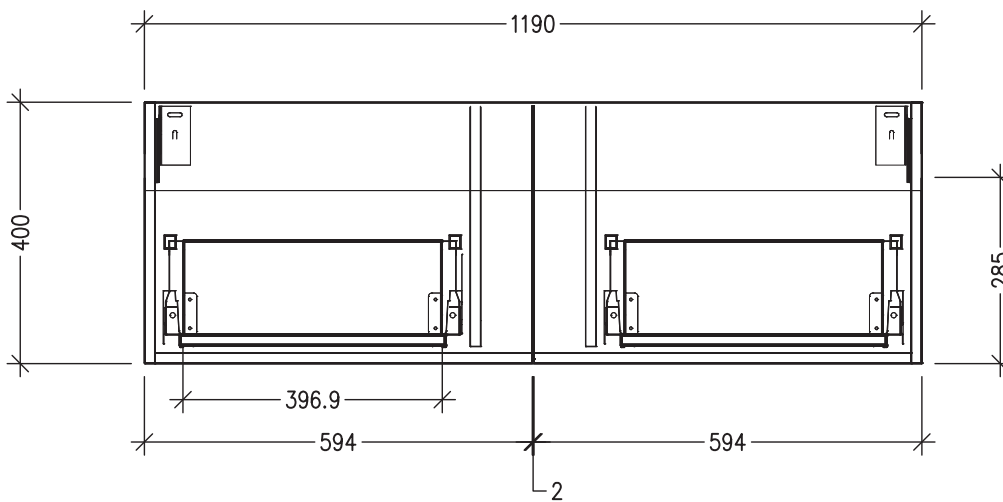

FRONT VIEW

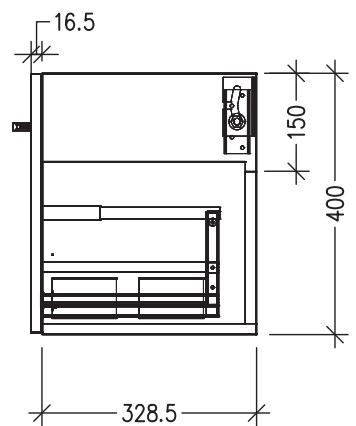

SIDE VIEW

SPECIFICATION SHEET

Designer Drawer/Door Fronts

BARNSELEY
18mm Inset Frame
Code: BL

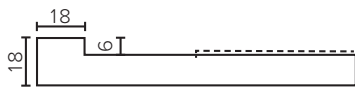
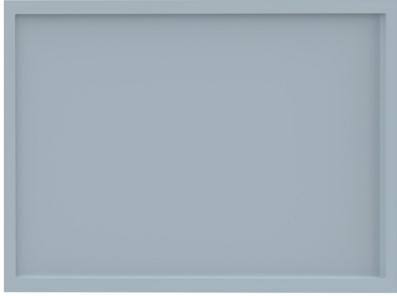

PRESTON
60mm Inset Frame
Code: PT

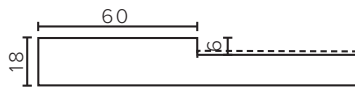
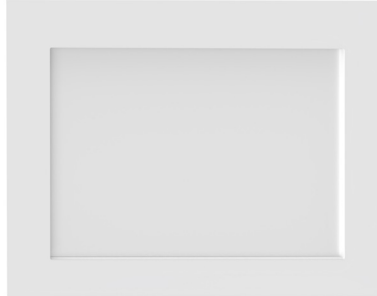

TURNBERRY
Ripple Design
Code: TB

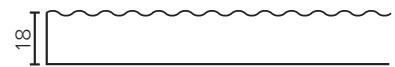

NEWPORT
V-Groove Panels
Code: NP

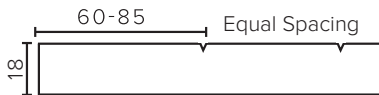

MIAMI
Little Wave
Code: MI

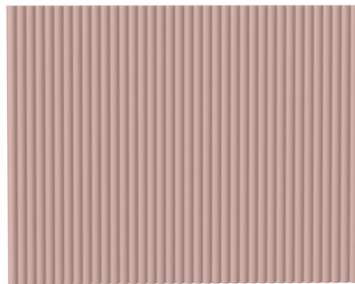

LAUREL
Fluted Lines
Code: LU

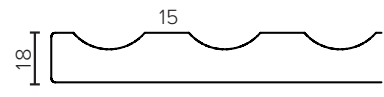
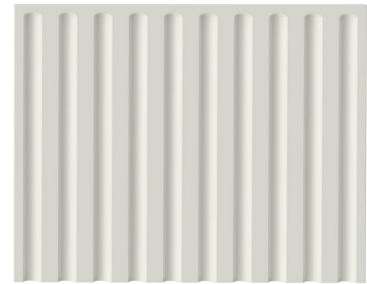

LINCOLN
Fence Style
Code: LN

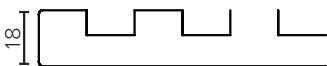

ASPEN
Scalloped Wave
Code: AP

