

# SPECIFICATION SHEET

## Francisco 500 1-Door Wall Hung Vanity



### Features

- 1-Door Wall Hung Vanity - *Colour options below*
- 50mm StoneCast Interchangeable Basin
- Soft Close Door - Left Hinge Only
- Cabinetry Handle - *Handle upgrade options*
- Designer Door Front - *Option available*
- Dimensions  
Cabinet: H400 x W492 x D240  
Basin: H50 x W500 x D250

### Cabinet Options

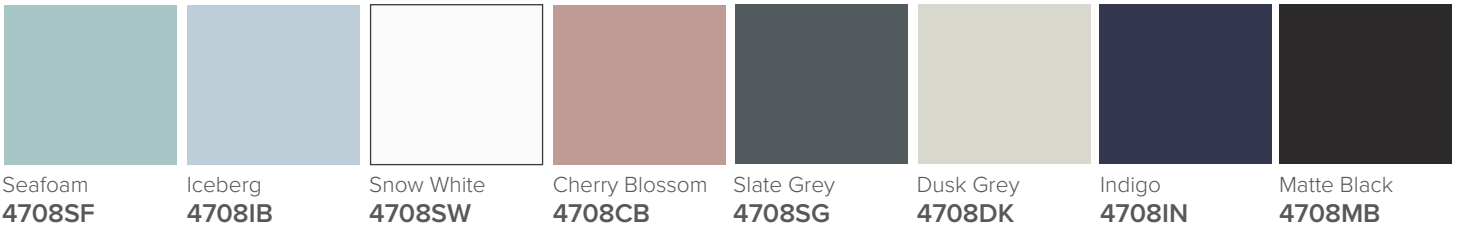

### Technical Details

Note: All measurements shown are in millimetres. Sizes are nominal.

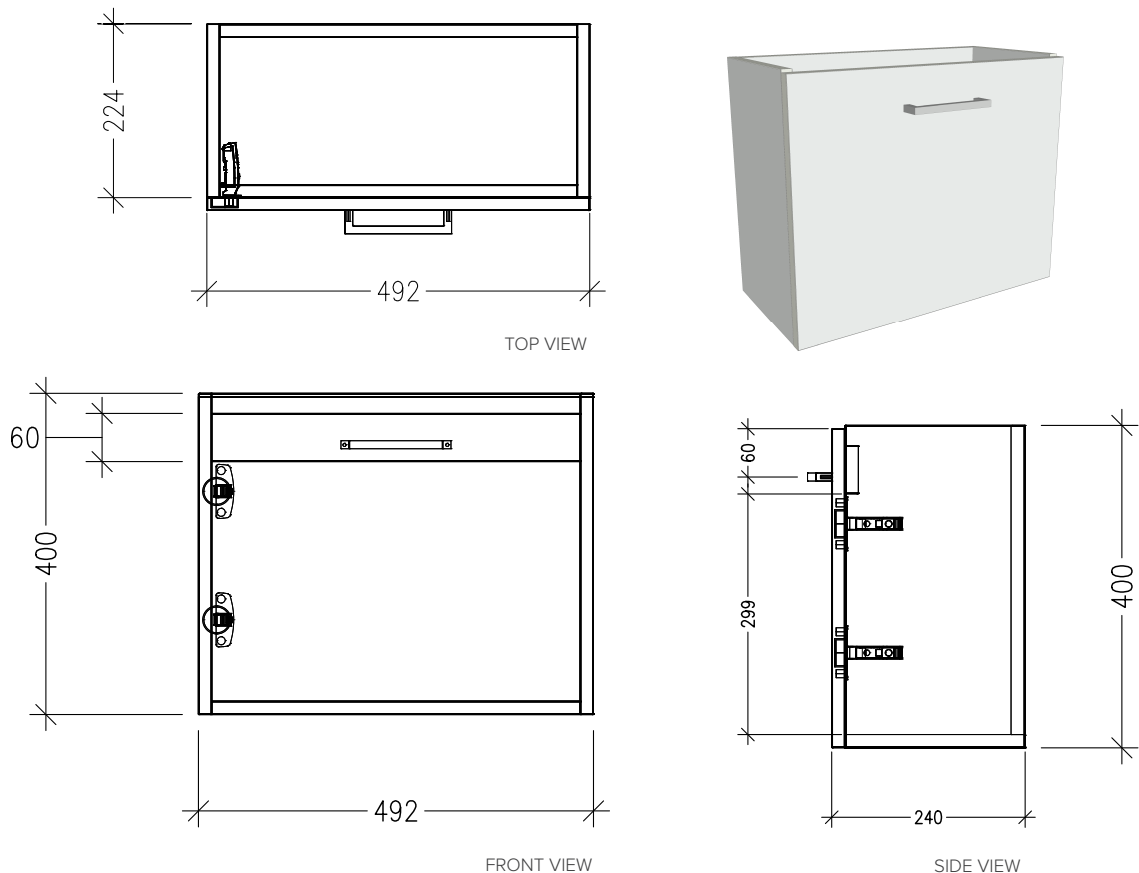

# SPECIFICATION SHEET

## Stonecast 500 Basin

StoneCast 50mm

PO50050

W500(±5) x D250 x H50

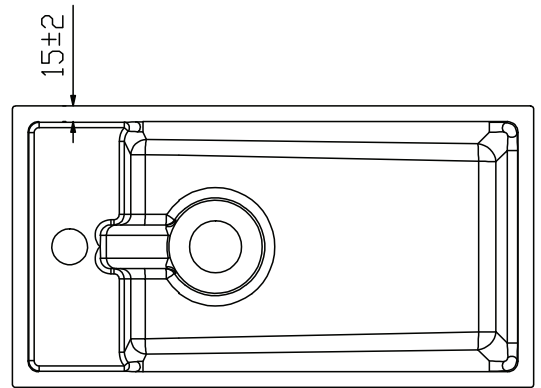
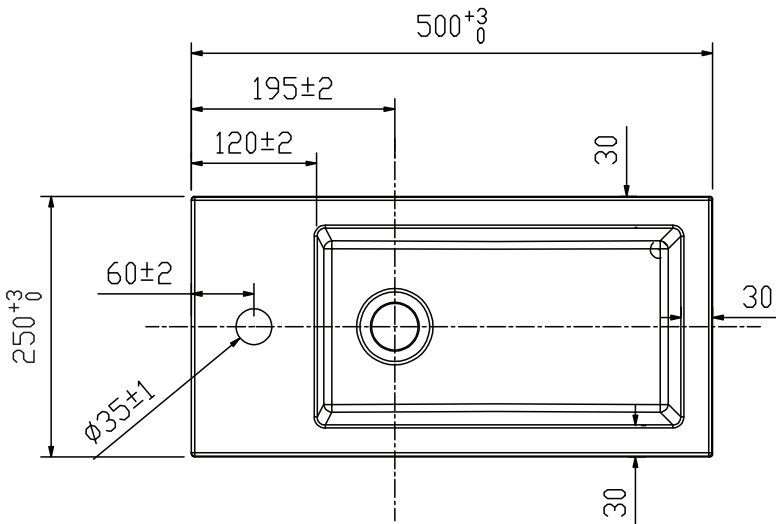
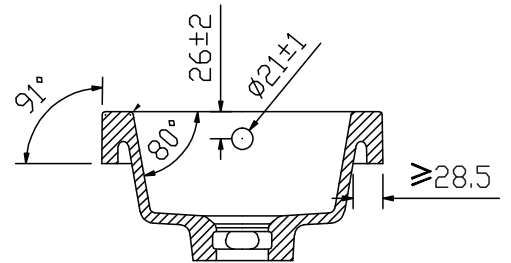
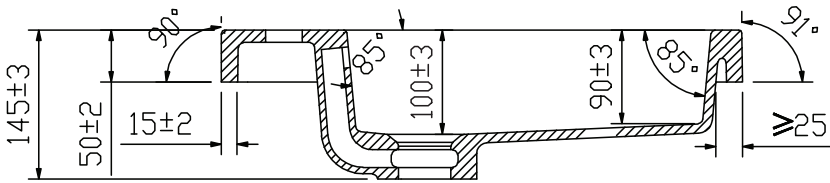
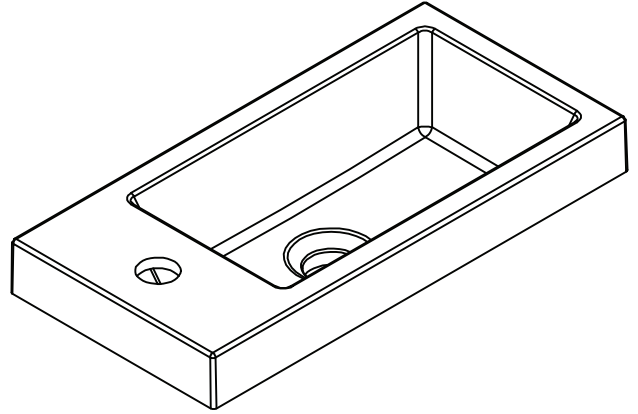

# SPECIFICATION SHEET

## Designer Drawer/Door Fronts

BARNSLEY  
18mm Inset Frame  
Code: BL

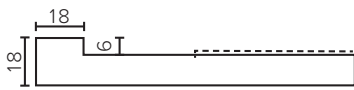
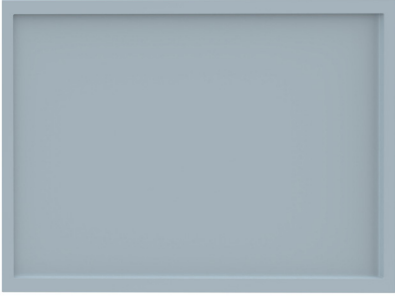

PRESTON  
60mm Inset Frame  
Code: PT

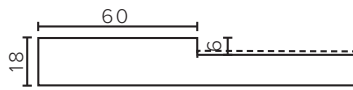
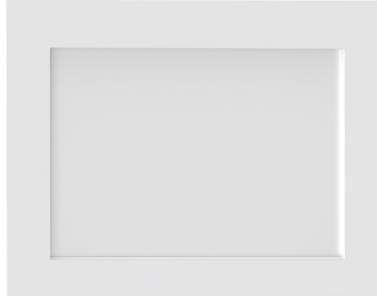

TURNBERRY  
Ripple Design  
Code: TB

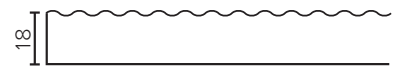

NEWPORT  
V-Groove Panels  
Code: NP

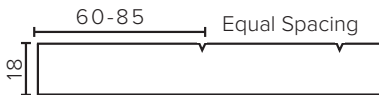

MIAMI  
Little Wave  
Code: MI

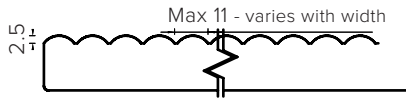
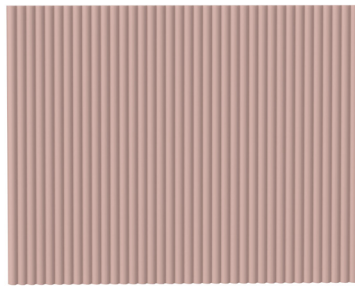

LAUREL  
Fluted Lines  
Code: LU

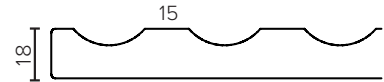
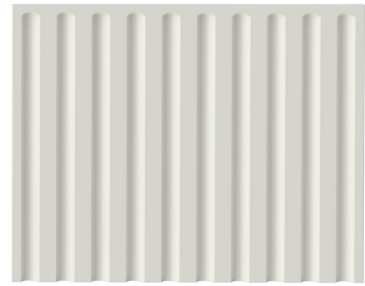

LINCOLN  
Fence Style  
Code: LN

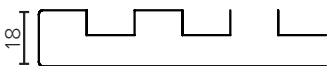

ASPEN  
Scallop Wave  
Code: AP

