

SPECIFICATION SHEET

Evoked High Rise Basin Mixer

Code: ET6102



Product Details

- Available in 5 different colours:
 - Chrome (Mirror Chrome)
 - Brushed Nickel (304 Stainless Steel)
 - Black (Chrome Black - Scratch Resistant)
 - Gunmetal (PVD)
 - Brushed Brass (PVD)
- 304 Stainless Steel Faucet Body and Casting Handle
- Lead-Free Stainless Steel Tapware (Materials comply with AS/NZS 4020:2018 for products in contact with drinking water)
- Minimum Pressure = 150kPa
- Maximum Operating Pressure = 500kPa (As per NZ Building Code AS/NZ 3500.01)
- Maximum Operating Temperature = 65 Degrees
- WELS Rating = 5 Star / 6 Litres per minute
- Watermark Neoperl Aerator
- Ø35 Sedal Ceramic Cartridge
- Spout Reach = 177mm
- Mains Pressure Only

Technical Details

Note: All measurements shown are in millimetres. Sizes are nominal.

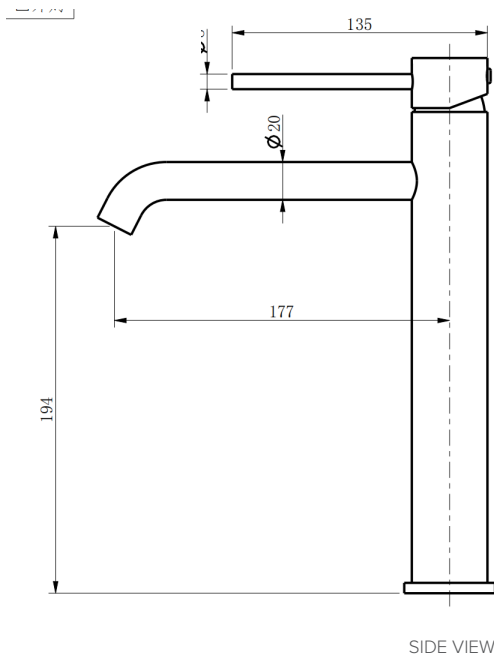

SIDE VIEW

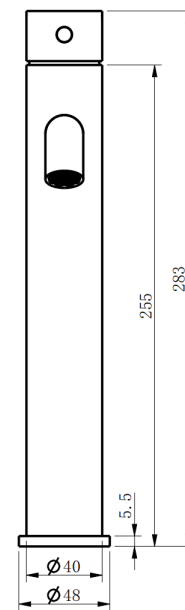

FRONT VIEW

