

SPECIFICATION SHEET

Brookfield 500mm Wall Hung Vanity



Features

- Wall Hung
- 2 Doors
- Interchangeable StoneCast Basin
- Laminate Woodgrain & Solid Colours on MR Board
- Dimensions: H450 x W500 x D250

Technical Details

Note: All measurements shown are in millimetres. Sizes are nominal.

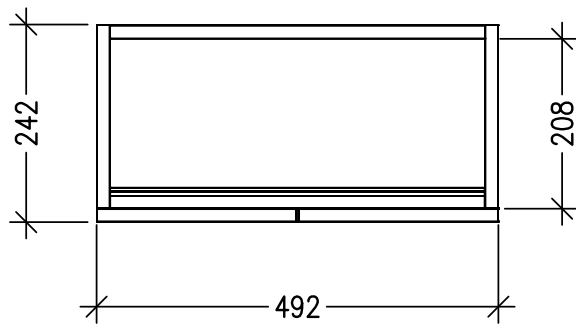

TOP VIEW

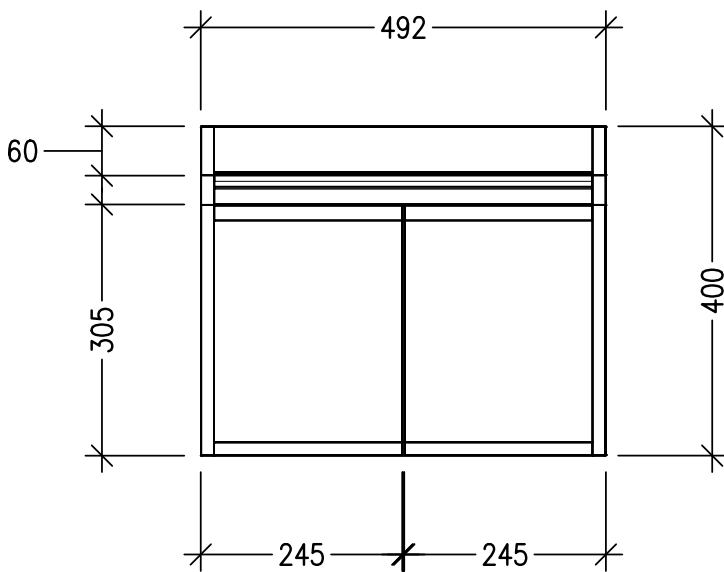

FRONT VIEW

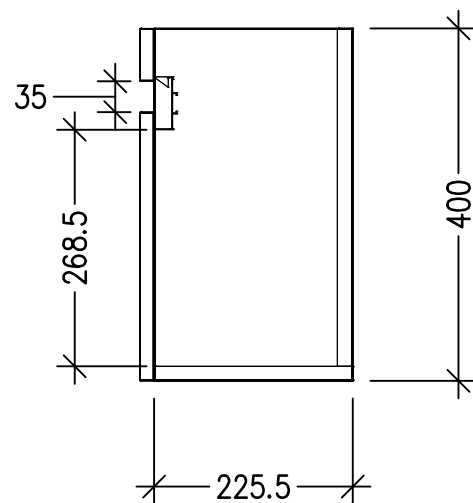

SIDE VIEW

SPECIFICATION SHEET

Stonecast 500 Basin

StoneCast 50mm

PO50050

W500(±5) x D250 x H50

