

SPECIFICATION SHEET

750 Angolo Curved Wall Hung Vanity (2 Drawer)

Newtech Code: 12021



Features

- 2 Drawer
- Soft close Hettich drawer runners
- Drawers with handle or negative detail
- Made of Oak Veener on Birch Ply
- Internal Carcass Option
Matte White - Standard
Anthracite - Upgrade cost applies
- Dimensions: H820 x W750 x D465

Technical Details

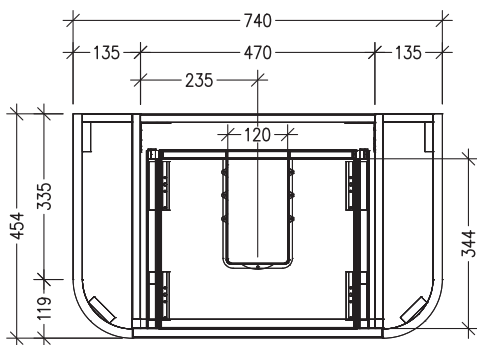

TOP VIEW

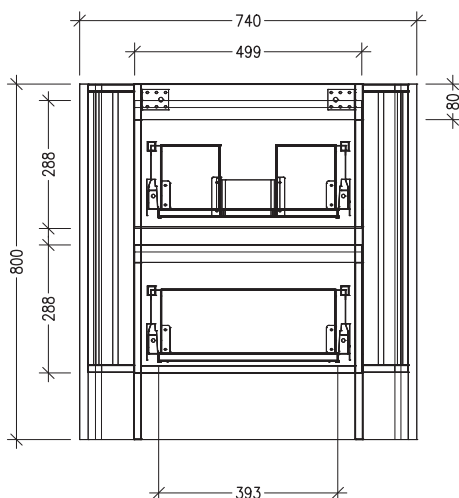

FRONT VIEW

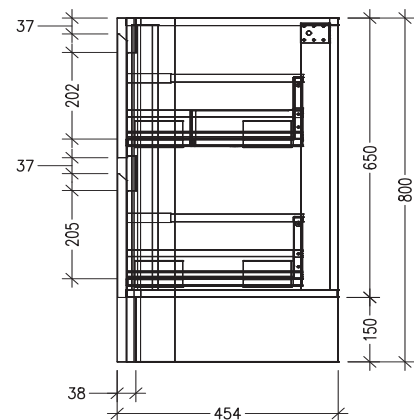

SIDE VIEW

Note: Drawings shown are for negative detail cabinets. When handle option is selected the drawer heights will be 321mm for top drawers and 323mm bottom drawers.