

**Q-Box-150 High Performance Inline Fan**

Code: 8177

exclusive to Newtech



The Q-Box is a high performance inline fan with an exhaust capacity of 433m<sup>3</sup>/hr. A low profile design that is perfect for installing in confined spaces. The centrifugal motor guarantees higher air flow while the acoustic internal lining results in ultra-quiet operation.

**Warranty**

- 2 years

**Applications and Installation**

- To be used in conjunction with internal grilles and ducting (not included)
- Works with long lengths of rigid or flexible ducting (up to 20m)\*
- Suitable for single or multiple room domestic and commercial applications including:
  - Bathrooms
  - Laundries
  - Kitchens and range hoods
  - Sub-floor
  - Supply air systems
- It is recommended that this product be installed by an industry professional (electrician or airconditioning installer)

\* Correctly sized ducting

**Manufacturer**



**Features and Benefits**

- Low profile design
- Internal acoustic lining
- Backward curved blades to ensure quiet operation and ample static pressure
- Ideal fan solution for centralised/multi-point ventilation solutions
- 2 speed motor
- Quick release clips for easy installation and maintenance

**Applications**

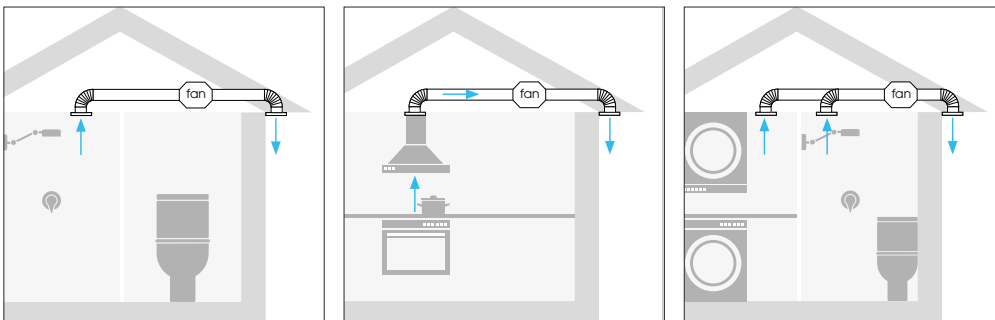

# Q-Box-150 High Performance Inline Fan

Code: 8177

## Specifications

Model	Item code	Volume m <sup>3</sup> /h (high/low)	Volume L/s (high/low)	Pressure (high/low)	Wattage (high/low)	Current A high/low	Noise dB(A)*	RPM
Q-box 100	1EQF100	280	78	381	75	0.36	32.5	2600
		180	50	325	63	0.28	27.5	1700
Q-box 150	1EQF150	433	120	421	79	0.39	37.5	2500
		222	62	338	64	0.3	29.2	1400

\*Measured at 3 metres

## Dimensions

Model	A	B	C	ØD	H	Kg
Q-box 100	492	304	253	98 Oval	143	6.7
Q-box 150	492	304	253	147 Oval	143	6.7

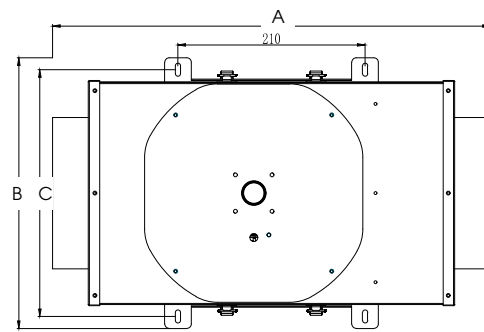
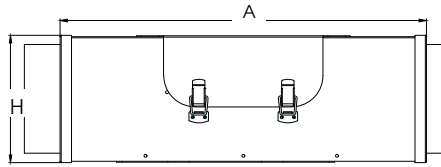

## Performance

