

SPECIFICATION SHEET

Savanna 1500mm Double Tier Wall Hung Vanity

Code: 2410

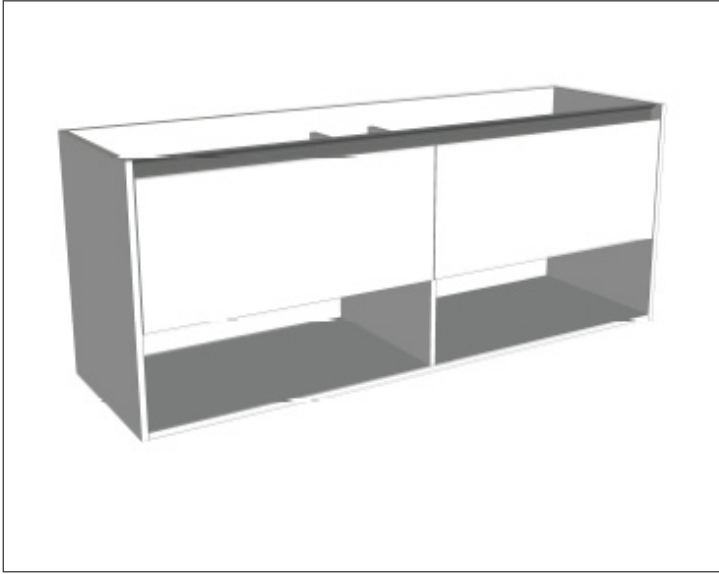

Features

- Wall Hung
- 2 Drawers with Extrusion, 2 Open Shelves
- Centre Basin
- Laminate Woodgrain & Solid Colours on MR Board
- Dimensions: H650 x W1500 x D453

Technical Details

Note: All measurements shown are in millimetres. Sizes are nominal.

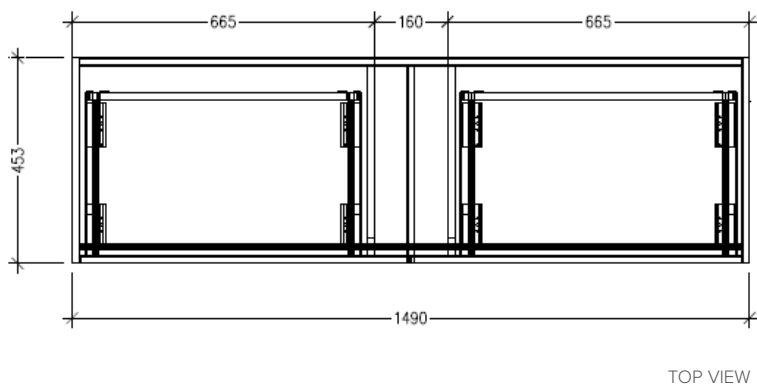
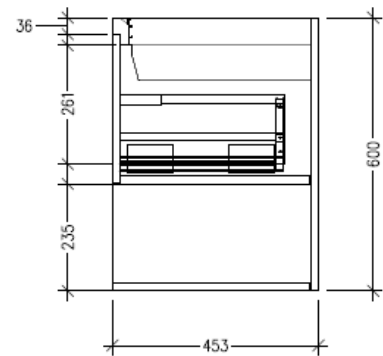
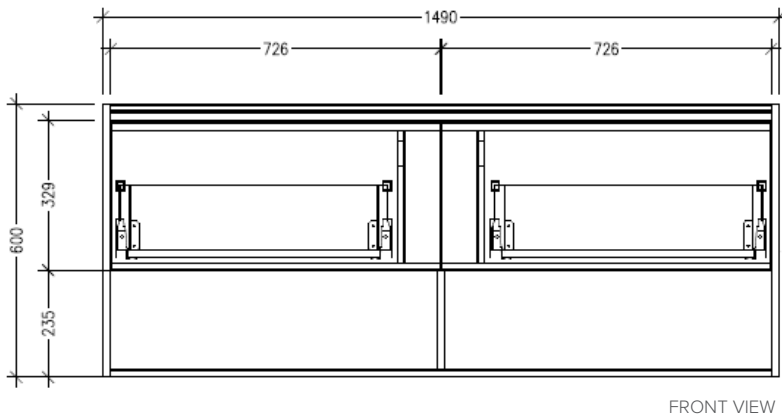

SPECIFICATION SHEET

Savanna 1500mm Double Tier Wall Hung Vanity

Code: 2410

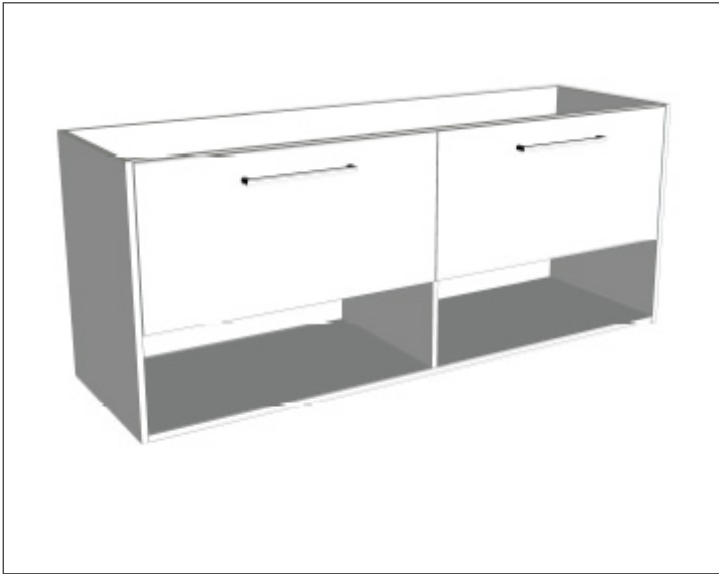

Features

- Wall Hung
- 2 Drawers with Handle, 2 Open Shelves
- Centre Basin
- Laminate Woodgrain & Solid Colours on MR Board
- Dimensions: H650 x W1500 x D453

Technical Details

Note: All measurements shown are in millimetres. Sizes are nominal.

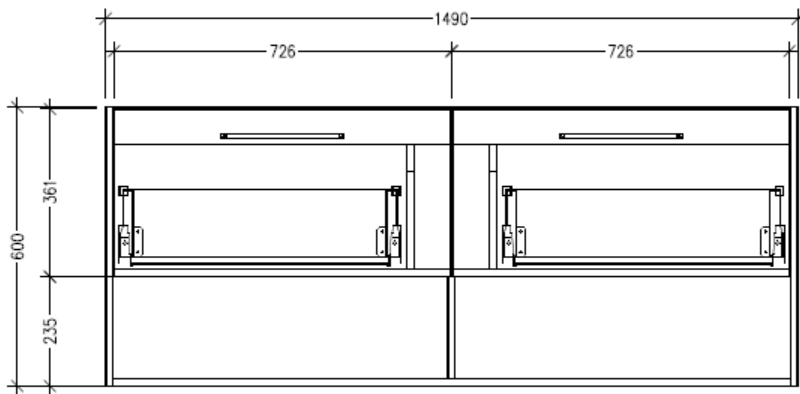

FRONT VIEW

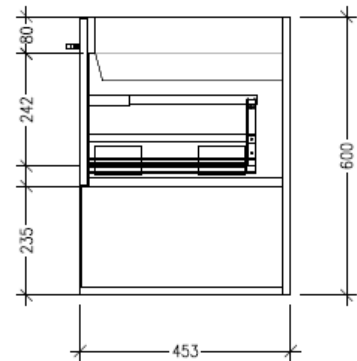

SIDE VIEW

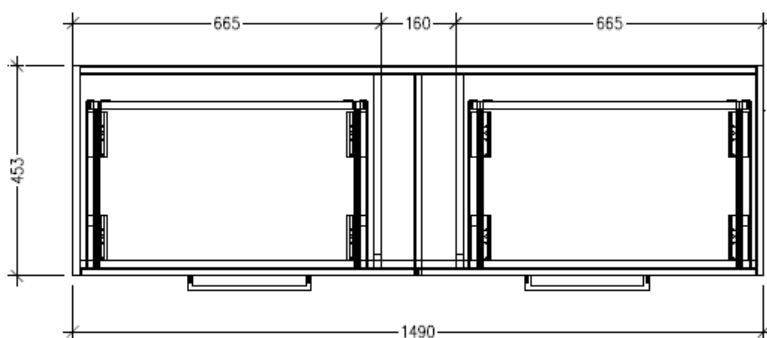

TOP VIEW

SPECIFICATION SHEET

Savanna 1500mm Double Tier Wall Hung Vanity

Code: 2410

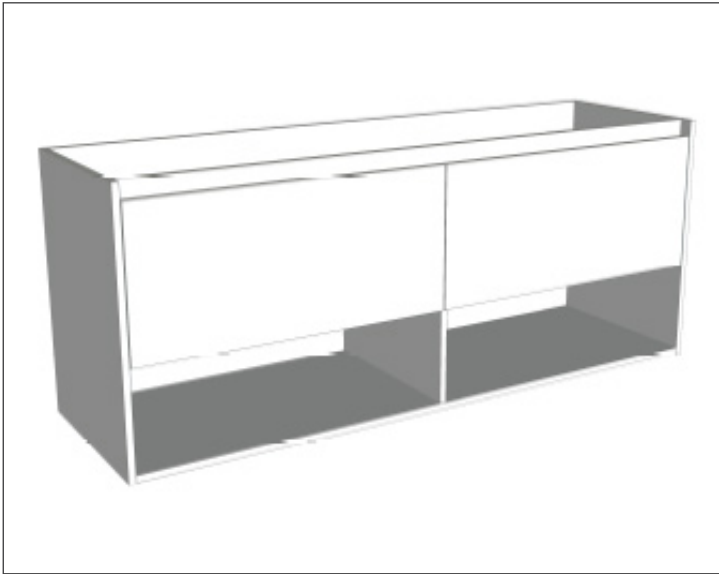

Features

- Wall Hung
- 2 Drawers with Negative Timber detail, 2 Open Shelves
- Centre Basin
- Laminate Woodgrain & Solid Colours on MR Board
- Dimensions: H650 x W1500 x D453

Technical Details

Note: All measurements shown are in millimetres. Sizes are nominal.

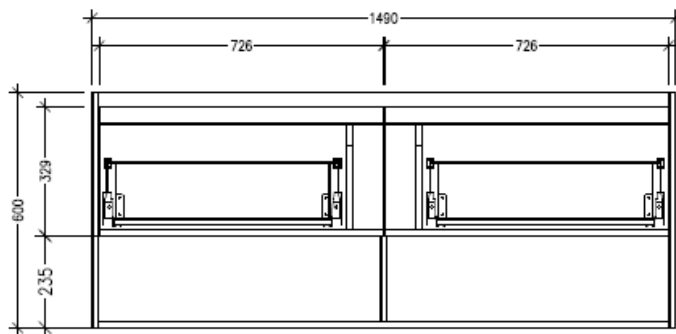

FRONT VIEW

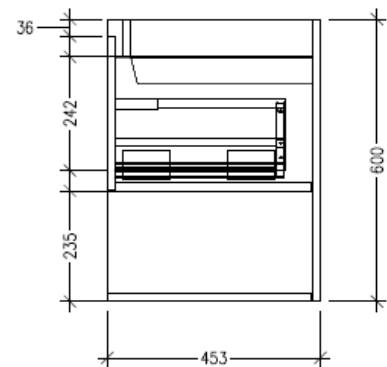

SIDE VIEW

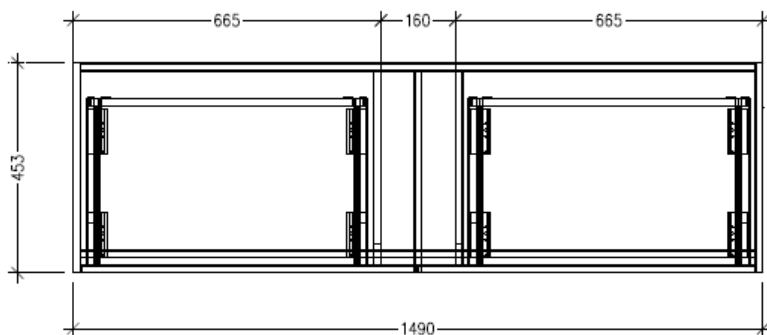

TOP VIEW